

DWDM Passive Component Test System

IQ-12004B



IL, PDL and ORL measurements
as a function of wavelength

C-band or C+L-band configuration

Comprehensive integrated software

Extensive data interpretation



Next-Generation DWDM Passive Component Test System

The optimum performance of DWDM systems and subsystems depends on the fast and accurate characterization of multiplexers, demultiplexers, filters and other passive components. Developers and manufacturers must test and control important parameters throughout the entire life cycle of a component, from research through to development, production and even deployment. These parameters include insertion loss, spectral uniformity, bandwidth, crosstalk, channel central wavelength, polarization dependence and optical return loss.

The IQ-12004B DWDM Passive Component Test System is EXFO's automated solution. EXFO designed the IQ-12004B from the ground up to streamline the testing of DWDM passive devices. The internal system bus enables efficient communication between the test system's components. Whether you're performing qualification or final production testing, the IQ-12004B DWDM Passive Component Test System delivers total ease-of-use, accuracy and speed.



IQ-12004B System Overview

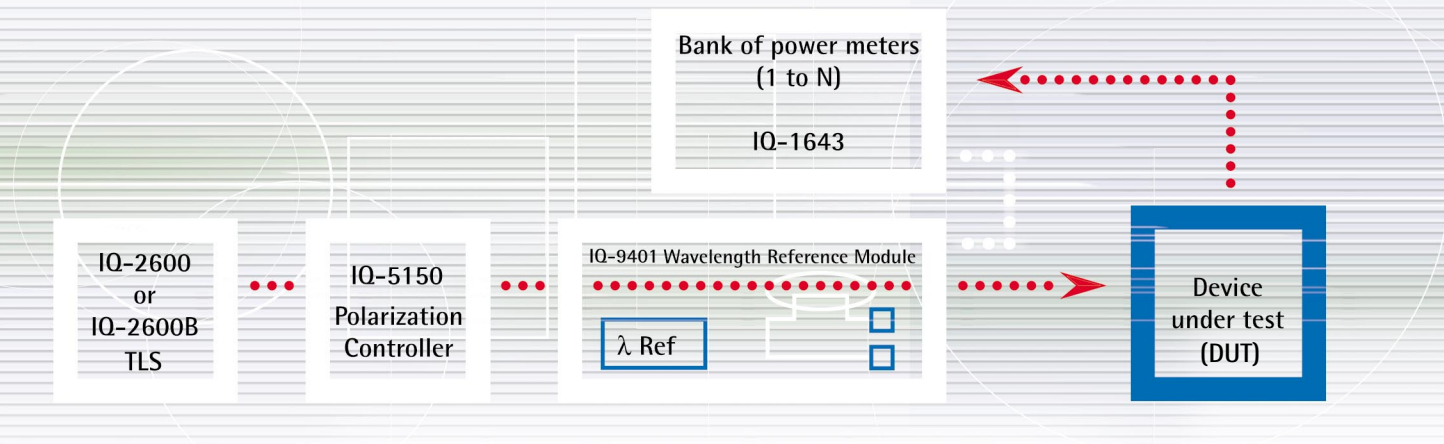

This test system sweeps a very low-noise tunable laser source, while measuring power on multiple channels; this provides quick testing time that is practically independent of the number of device ports. The wavelength reference module ensures accuracy by providing a fast and continuous wavelength and power reference throughout the sweep. PDL measurements, calculated using the Mueller Matrix method, are optional and provide PDL vs. wavelength across the complete range. The attenuation and PDL sweeps are completed without any fiber handling.

The test system also provides ORL vs. wavelength measurement. This feature is standard, and the measurement is performed by a dedicated detector in the IQ-9401 Wavelength Reference Module.

High-resolution testing of single and multichannel DWDM passive components generates vast quantities of data. The IQ-12004B system has been designed to take advantage of internal high-speed data transfer, resulting in reduced measurement and data transfer time.

Test Equipment

■ Controller

- The IQ-12004B system is available with a choice of controller units, either the IQ-203 Control Unit or a high-speed PC.
- The IQ-203 Control Unit is recommended for testing low-channel-count systems (≤ 8 channels) where it is important to minimize bench space requirements. The combination of IQ-203 Control Unit and IQ-206 Expansion Unit makes for a complete and compact stand-alone system.
- The PC controller option is recommended for testing high-channel-count systems (> 8 channels) or when minimizing testing time is of utmost importance.

■ IQ-206 Expansion Unit

This expansion unit houses the required test instruments. Up to four expansion units may be connected to the IQ-203 Control Unit.

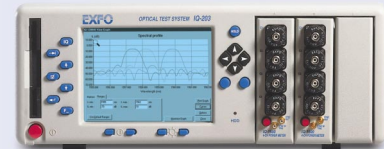

■ Tunable Laser Source (TLS)

Choice of two different modular two-slot tunable laser sources:

- The IQ-2600 covers the 1520 nm to 1570 nm (C-band) range
- The IQ-2600BT covers the 1510 nm to 1612 nm (C+L-band) range



■ IQ-5150 Polarization State Adjuster (PSA)–(Optional)

- A two-slot module
- Generates four orthogonal states of polarization
- Designed around bulk-optic components
- Uses the Mueller Matrix calculation method for PDL measurement
- No fiber handling required



■ IQ-9401 Wavelength Reference Module (WRM)

- A two-slot module
- Gives fast and accurate absolute wavelength reference
- Provides dynamic power reference for attenuation and polarization-dependent loss (PDL) measurements
- Performs the optical return loss (ORL) measurements
- Provides synchronization signal



■ IQ-1643T Power Meter (four channels)

- Four detectors in a one-slot module
- Optimized for low polarization dependence
- Optimized for low spectral interference
- Optimized for fast autoranging
- Direct memory access for fast data transfer
- High sensitivity for high-loss measurements



Comprehensive, Easy-to-Use Software

Configure

Supervisors can configure a database of frequently tested components that contains acceptance criteria for evaluating whether or not a component meets the desired requirements. This is a simple two-step procedure that configures not only the Pass/Fail limits, but, also, the IQ-12004B scan settings and analysis parameters.

Step One: Create a database containing frequently tested components.

Step Two: Once the ports are defined, the DUT configuration screen prompts you to enter a unique part number along with

- the number of ports
- the type of each port
- the wavelength of each port
- the analysis range and scan resolution
- data analysis parameters

The window for optical port definition configures exacting Pass/Fail limits for all parameters. This includes IL, crosstalk, flatness, central wavelength, bandwidth, PDL and ORL. There is no practical limit to the number of ports that can be defined.

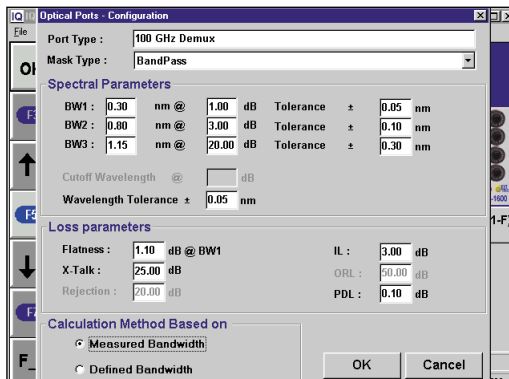

DUT port configuration

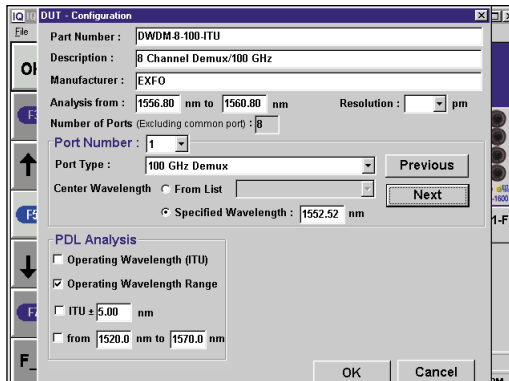

DUT configuration

Select

During normal functioning, the system operator simply selects a component (unique part number) and starts the test. At this stage, all the test limits and test parameters will automatically be selected. This mode of operation is ideal for high-volume production testing.

In addition, the system can test generic devices or components with unknown or undetermined characteristics. The system is simply configured by the operator (wavelength range, resolution and number of channels) and is ready to start testing. This mode of operation is perfect for R&D, qualification, receiving inspection and early production testing.

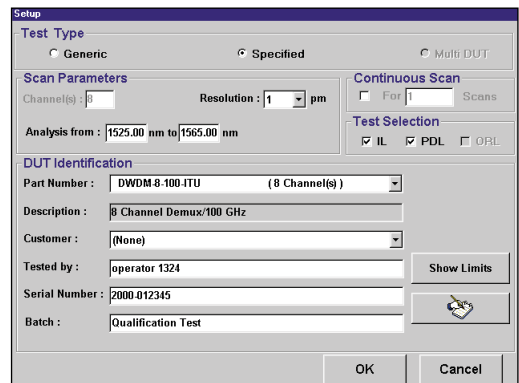

Testing a specified component

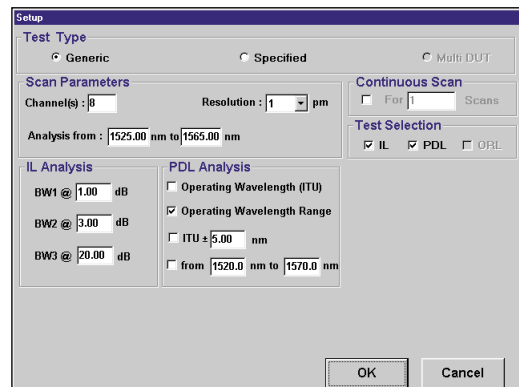

Testing a generic component

Total Flexibility

The IQ-12004B Passive Component Test System comes with a complete software package that gets you up and running the day the system is installed. EXFO developed the GPIB and COM/DLL remote interfaces to enable easy and efficient integration of the IQ-12004B system into your software applications. Simple, high-level commands allow even novice programmers to quickly develop customized testing routines with either interface.

GPIB Remote Interface

Perform insertion loss and PDL measurements with a simple GPIB command (e.g., ACQ: ILPDL). The IQ-12004B remote interface interprets this command and controls all instruments. EXFO's done all the hard work for you.

A complete set of commands is available, comprised of initialization, calibration, IL, ORL, PDL measurements and many individual instrument controls.

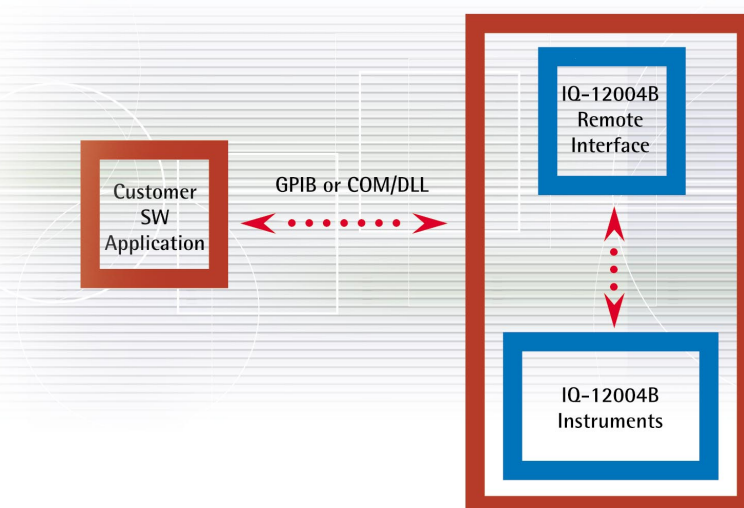

COM/DLL Remote Interface

Achieve greater programming efficiency. All system functions are also available for direct DLL control, either locally or over an Ethernet (DCOM) connection. Additional productivity gains are also observed because the GPIB bus is no longer required and is replaced by either direct memory transfer or a network link.

Perform reference
Perform IL measurements
View results

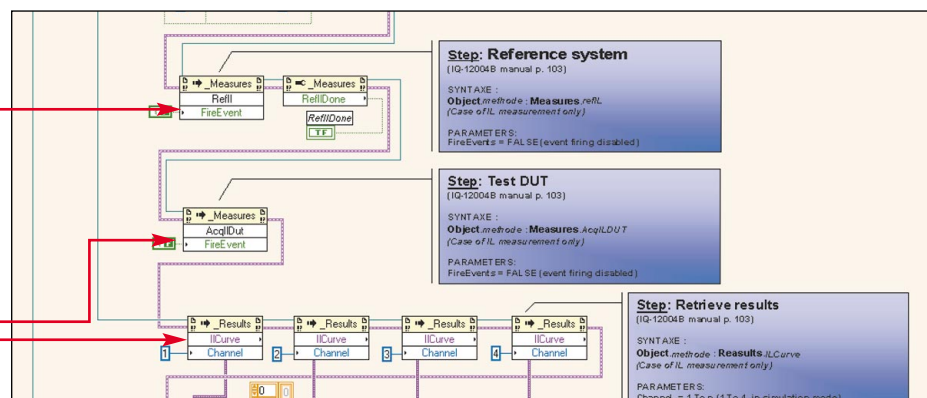

Simple LabVIEW™ example using direct DLL control

Simulation Mode

Develop software applications without tying up costly hardware by initializing the IQ-12004B remote interface in Simulation mode. This mode also allows several programmers to develop software in parallel.

Results That Speak Volumes

Insertion Loss Accuracy

The IQ-12004B system can measure insertion loss (IL) as a function of wavelength for any passive component over the C-band or the C+L-band. The measurement shown was made soon after a reference was performed with a patchcord connected directly between the WRM and the optical power meter. An ideal response would be a perfectly flat line at 0.000 dB. According to the data collected, the measurement ripple is around 0.001 dB. This indicates the level of performance that can be expected under ideal conditions.

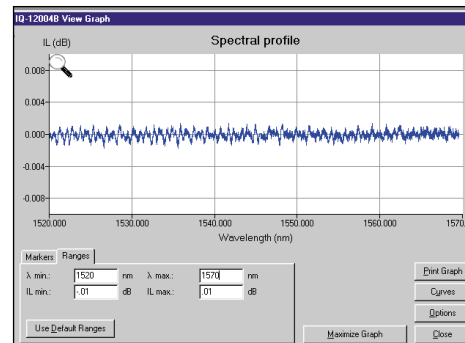

Outstanding Dynamic Range

The IQ-12004B system also has an excellent dynamic range or optical rejection ratio (ORR) as shown by the filter measurement opposite. To achieve this type of dynamic range from a fast single measurement scan, many parameters have to be considered.

This is what you will need:

- A very low noise tunable laser source
- A fast autoranging optical power meter
- A high sensitivity optical power meter

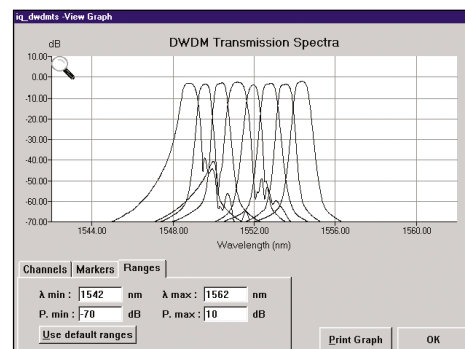

Accurate PDL vs. Wavelength Measurement

It is becoming increasingly important to be able to measure PDL as a function of wavelength for many DWDM passive components. For bandpass components, PDL must be measured across the passband. For other components, such as attenuators or gain equalization filters, it is important to measure PDL across the entire range.

The IQ-12004B uses the Mueller Matrix four-state method. The graph shown opposite plots data from a nominal 0.05 dB PDL specimen measured by both the IQ-12004B and a polarization-scrambling apparatus. As can be seen, there is very close correlation, in addition, measurement repeatability is exceptional.

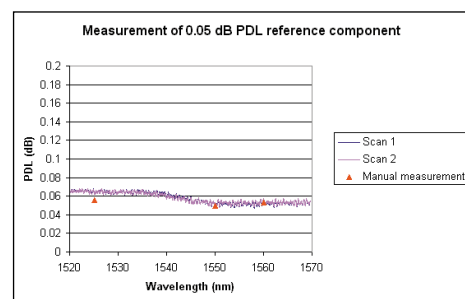

ORL Measurement as a Function of Wavelength

The IQ-9401 Wavelength Reference Module has a return loss measuring detector connected to the output coupler. The ORL circuit uses an optical continuous wave reflectometer (OCWR) with a tunable light source, allowing ORL to be measured as a function of wavelength.

An added advantage of this configuration is the ability to measure the reflected spectrum of an FBG without requiring an additional coupler or circulator.

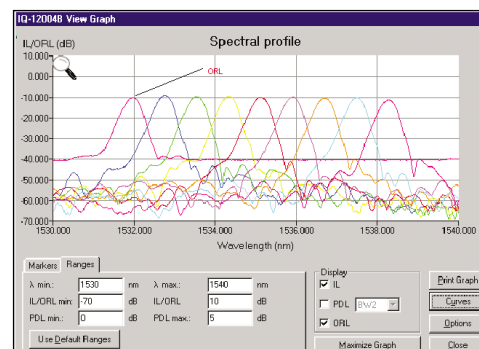

Test

Measure All Channels Simultaneously

The IQ-12004B performs measurements at top speed and analyzes data rapidly, enabling the system operator to continue testing more devices. Tabulated test results clearly indicate if a device has passed or failed the test. In addition, they provide a detailed summary of all interpreted data, including central wavelength, insertion loss, flatness, PDL, ORL and a comprehensive crosstalk matrix.

Test Results Are Easy to Read and Interpret

Graphical test results and analysis tools are also available for more detailed evaluation. Includes attenuation, PDL and ORL data as well as user-defined scales and markers. The IQ-12004B DWDM Passive Component Test System delivers everything expected of a high-performance test instrument.

DWDM Components View Results								
DWDM Components Information								
Part Number : Demultiplexer				S/N : 00001				
Description : 100 GHz - 8 channel				Date : 2000.02.24				
Test Results	Limits							Crosstalk
	Out 1	Out 2	Out 3	Out 4	Out 5	Out 6	Out 7	
Design Wavelength (nm)	1548.520	1549.324	1550.128	1550.930	1551.720	1552.520	1553.330	1
Measured Wavelength (nm)	1548.562	1549.324	1550.116	1550.950	1551.720	1552.526	1553.299	1
Difference (nm)	0.04	0.01	0.00	0.03	0.00	0.01	0.03	1
Insertion Loss (dB)	3.04	3.59	3.15	2.55	4.06	3.22	3.34	1
PDL (dB)	0.05	0.04	0.09	0.07	0.12	0.15	0.17	1
PDL (dB) at -0.1 nm	0.09	0.16	0.10	0.13	0.19	0.15	0.16	1
PDL (dB) at +0.1 nm	0.05	0.05	0.07	0.07	0.08	0.13	0.21	1
BW1: @ 1.00 dB (nm)	0.44	0.32	0.40	0.45	0.28	0.44	0.42	1
BW2: @ 3.00 dB (nm)	0.60	0.47	0.53	0.64	0.44	0.56	0.55	1
BW3: @ 20.00 dB (nm)	1.15	0.85	0.90	1.18	0.89	1.01	0.93	1
Rejection (dB)	0.00	0.00	0.00	0.00	0.00	0.00	0.00	1
Flatness (dB)	1.00	1.00	1.00	1.00	1.00	1.00	1.00	1
Maximum Crosstalk (dB)	29.58	31.86	26.57	23.46	24.74	23.48	32.85	1
Mask Type	Band Pass	Band Pass	Band Pass	Band Pass	Band Pass	Band Pass	Band Pass	1
Pass/Fail Test Post	Pass	Pass	Pass	Pass	Pass	Pass	Pass	1

Test Status: **Pass** Show Graph OK

Tabulated test results

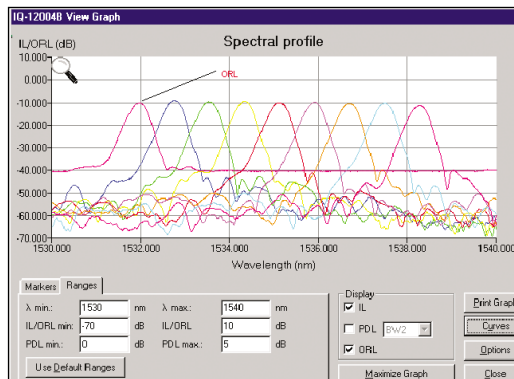

Graphical test results

Manage Data

The IQ-12004B Passive Component Test System includes extensive data management features, such as network connection and compatibility, as well as a database browser permitting off-line or post-measurement analysis. Comprehensive data management enables all parameters and results to be saved to an Access™-compatible .MDB database. The software also offers file-transfer utilities such as, for example, TXT export.

DWDM Component test report												
Part: 100 GHz Channel 100 GHz						Manufactured by:						
Description: 8 Channel Demux						Tested by: MC						
Part No: 0000						Batch:						
TEST STATUS: Fail												
Design Wavelength (nm)	Out 1	Out 2	Out 3	Out 4	Out 5	Out 6	Out 7	Out 8	Out 9	Out 10	Out 11	Out 12
Measured Wavelength (nm)	1548.500	1549.310	1550.110	1550.910	1551.710	1552.510	1553.310	1554.110	1554.910	1555.710	1556.510	1557.310
Difference (nm)	0.000	0.000	0.000	0.000	0.000	0.000	0.000	0.000	0.000	0.000	0.000	0.000
Insertion Loss (dB)	2.911	3.405	2.919	2.307	3.800	2.904	2.743	3.000	2.904	2.743	3.000	2.904
PDL (dB)	0.00	0.00	0.00	0.00	0.00	0.00	0.00	0.00	0.00	0.00	0.00	0.00
PDL (dB) at -0.1 nm	0.00	0.00	0.00	0.00	0.00	0.00	0.00	0.00	0.00	0.00	0.00	0.00
PDL (dB) at +0.1 nm	0.00	0.00	0.00	0.00	0.00	0.00	0.00	0.00	0.00	0.00	0.00	0.00
Rejection @ 10.00 dB (nm)	0.00	0.00	0.00	0.00	0.00	0.00	0.00	0.00	0.00	0.00	0.00	0.00
Rejection @ 20.00 dB (nm)	0.00	0.00	0.00	0.00	0.00	0.00	0.00	0.00	0.00	0.00	0.00	0.00
Rejection @ 30.00 dB (nm)	0.00	0.00	0.00	0.00	0.00	0.00	0.00	0.00	0.00	0.00	0.00	0.00
Flatness (dB)	1.00	1.00	1.00	1.00	1.00	1.00	1.00	1.00	1.00	1.00	1.00	1.00
Maximum Crosstalk (dB)	28.04	30.88	24.71	23.87	24.79	23.10	23.51	23.00	23.51	23.00	23.51	23.00
Mask Type	Band Pass	Band Pass	Band Pass	Band Pass	Band Pass	Band Pass	Band Pass	Band Pass	Band Pass	Band Pass	Band Pass	Band Pass
Pass/Fail Test Post	Fail	Pass	Pass	Pass	Fail	Pass	Pass	Pass	Pass	Pass	Pass	Pass

Select a standard or customized report.

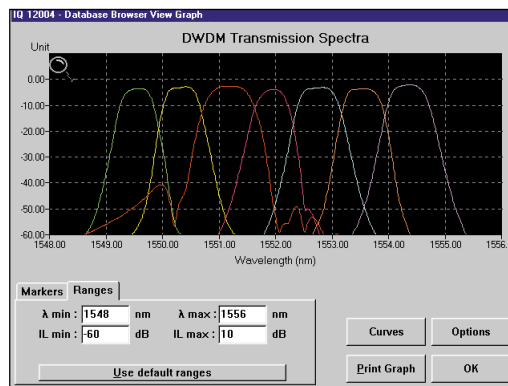

Use the Database Browser for reviewing and analyzing archived data.

Complete Device Characterization at the Touch of a Button

A Complete Data Analysis Package

Insertion Loss

Calculates the IL value as the highest attenuation value within the boundaries of a channel, i.e., $ITU \pm DI$ (where DI is a user-defined parameter or, alternatively, a measured value).

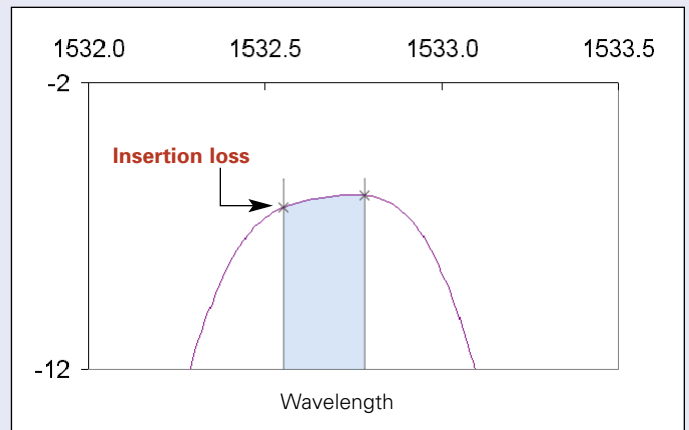

Flatness

Calculates passband flatness as the difference between the maximum and minimum attenuation over the defined (or optionally measured) passband of the DUT.

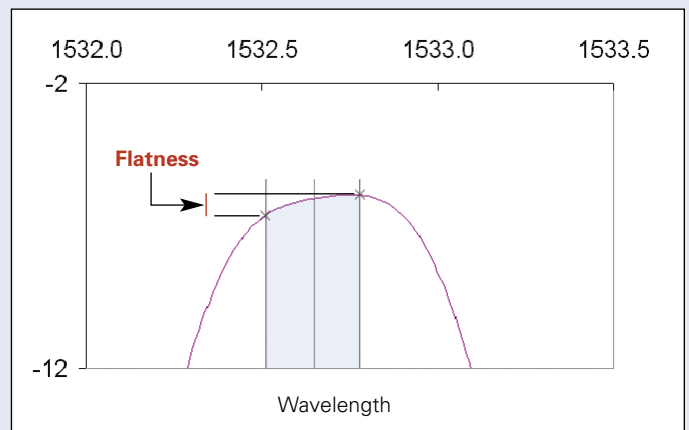

Central Wavelength

Measures the central wavelength as the midpoint between the upper and lower 3 dB wavelengths.

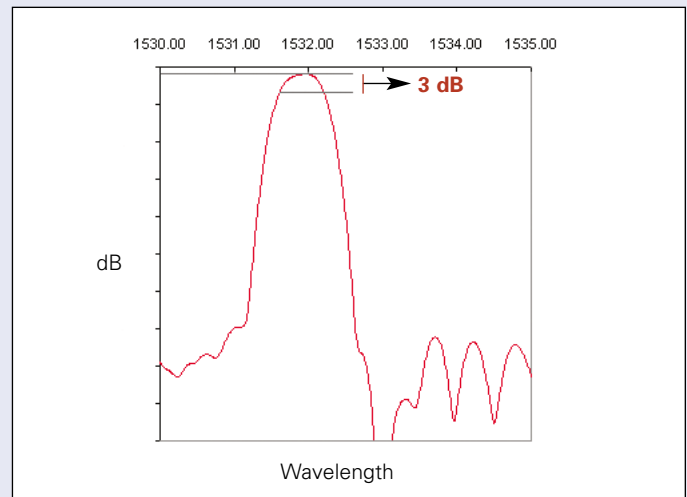

Bandwidth

Measures bandwidth at three different user-defined levels. The low-loss bandwidth (BW1 in the software) determines the passband of the device and calculates IL, ripple and crosstalk.

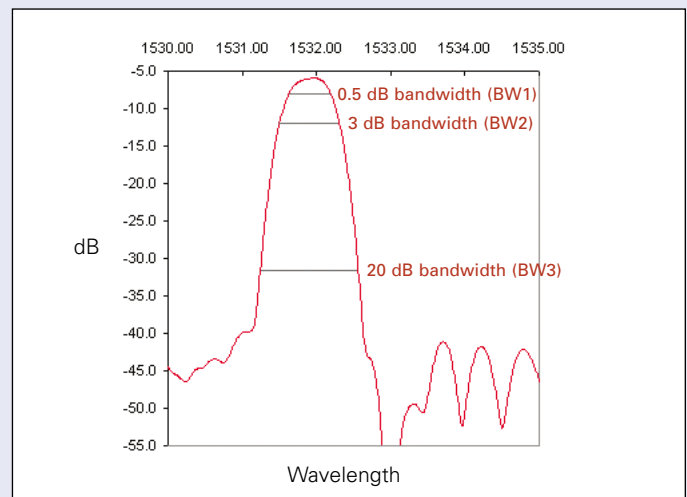

Crosstalk

Measures crosstalk as the worst-case value, i.e., the difference between the highest loss in-band (channel A shown on the right) and the lowest loss in the bands of adjacent channels. The software allows the bands to be either defined or measured.

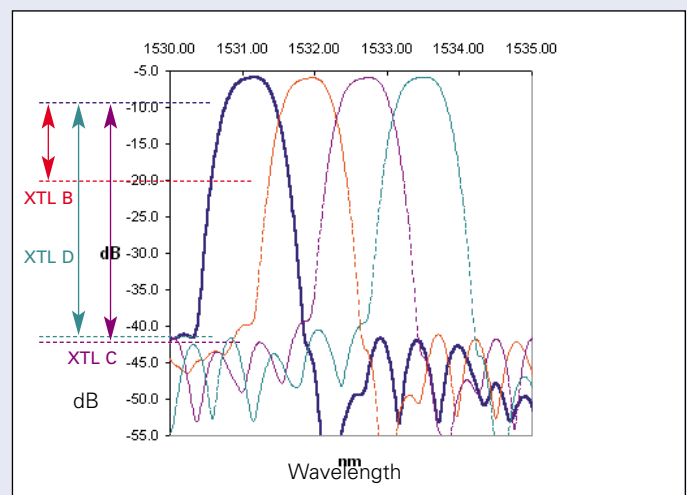

Specifications

Specifications ¹	Source Options	
	IQ-2600	IQ-2600BT
Testing time ²	< 30 s	< 18 s for 1 channel < 25 s for 40 channels
Sampling resolution ³	0.01 nm	0.005 nm, 0.01 nm, 0.02 nm, and 0.04 nm
Wavelength uncertainty ⁴	± 0.010 nm	± 0.005 nm
	± 0.005 nm typical	
Wavelength repeatability ⁴ (2σ)	± 0.003 nm	± 0.001 nm
Wavelength range	1521nm to 1569 nm	1511 nm to 1611 nm
Loss measurement uncertainty ^{5,6}		± 0.05 dB (0 to 50 dB loss)
Loss measurement repeatability ^{5,6}		± 0.01 dB (0 to 50 dB loss)
Loss measurement range ⁶		0 to 75 dB
Loss measurement resolution		0.001 dB
Optical rejection ratio ⁷		> 60 dB
PDL measurement resolution		0.001 dB
PDL uncertainty ^{6,8}	1520 nm to 1570 nm	± (0.02 dB + 5 % of PDL DUT)
	1511 nm to 1611 nm	± (0.03 dB + 5 % of PDL DUT)
PDL range		0 to 10 dB
ORL uncertainty ⁹		± 0.5 dB (0 to 45 dB)
		± 1 dB (45 to 50 dB)
ORL range ⁹		0 to 65 dB
Number of channels ¹⁰		80
Operating temperature		23 °C ± 3 °C
Storage temperature		-10 °C to 50 °C

Notes

- All uncertainties are reported with a level of confidence = 95 %, after 60 minutes operating at constant temperature.
- Testing time calculated for a single Insertion Loss measurement using a system with a Pentium III processor and includes data processing time for 1 channel (unless otherwise specified) at a sampling resolution of ≥ 0.01 nm over a range of 50 nm. For PDL test time, 3 additional scans are required. For ORL, 1 additional scan is required.
- This is a typical value; actual sampling resolution may vary across the scan.
- Applies to 0.005 nm and 0.01 nm sampling resolution, after user calibration.
- Valid for a spectrally uniform component. Does not include uncertainties due to connector or connector adapter.
- With > -5 dBm input to the DUT.
- For DWDM bandpass components designed for ≤ 100 GHz channel spacing.
- Valid after performing a Null measurement and a Reference measurement on a low loss spectrally uniform component terminated with a non-angled connector. Does not include uncertainties due to connector or connector adapter.
- Specified without the IQ-5150 Polarization State Adjuster connected in the optical path. With the IQ-5150 connected, the reduction in the dynamic range is ≈ 5 dB.
- With the PDL option, the maximum number of channels is 72.

Standard Accessories

System controller with keyboard, mouse, SVGA monitor, network card, OS
 Mainframe and/or expansion unit as required
 IQ-9401 Wavelength Reference Module
 ORL reflection reference
 IQ-12004B software
 Interconnecting patchcords
 Instruction manual
 Calibration certificate
 DLL control

Options

GP-222	GPIB device card (PC)
GP-223	GPIB controller card
Rack-IQ	Rack without fiber management
Rack-IQ-FM	Rack with fiber management
FM	Fiber management

Ordering Information

IQ-12004B- MM-MM-MM-PP-MM

MM: Controller Option

IQ = IQ-203

PC

MM: Source Option

S1 = IQ-2600

S2 = IQ-2600BT

MM: Polarization Option

00 = None

P1 = PDL Option

PP: Number of Expansion Units

61 = 1 additional IQ-206 Expansion

62 = 2 additional IQ-206 Expansions

63 = 3 additional IQ-206 Expansions

MM: Number of Channels

04 = 4 channels

08 = 8 channels

12 = 12 channels

16 = 16 channels

XX = multiples of 4 up to 80



CORPORATE HEADQUARTERS	465 Godin Avenue	Vanier (Quebec) G1M 3G7 CANADA	Tel.: 1 418 683-0211 . Fax: 1 418 683-2170
EXFO AMERICA	1201 Richardson Drive, Suite 260	Richardson TX 75080 USA	Tel.: 1 800 663-3936 . Fax: 1 972 907-2297
EXFO EUROPE	Le Dynasteur, 10/12 rue Andras Beck	92366 Meudon la Forêt Cedex FRANCE	Tel.: +33.1.40.83.85.85 . Fax: +33.1.40.83.04.42
EXFO ASIA-PACIFIC	151 Chin Swee Road, #03-29 Manhattan House	SINGAPORE 169876	Tel.: +65 333 8241 . Fax: +65 333 8242
TOLL-FREE (USA and Canada)	Tel.: 1 800 663-3936	www.exfo.com • info@exfo.com	

EXFO is certified ISO 9001 and attests to the quality of these products. This device complies with Part 15 of the FCC Rules. Operation is subject to the following two conditions: (1) this device may not cause harmful interference, and (2) this device must accept any interference received, including interference that may cause undesired operation. EXFO has made every effort to ensure that the information contained in this specification sheet is accurate. However, we accept no responsibility for any errors or omissions, and we reserve the right to modify design, characteristics and products at any time without obligation. Units of measurement in this document conform to SI standards and practices. **Contact EXFO for prices and availability or to obtain the phone number of your local EXFO distributor.** For the most recent version of this spec sheet, please go to the EXFO Web site at <http://www.exfo.com/support/techdocs.asp> In case of discrepancy, the Web version takes precedence over any printed literature.

