

End-to-End Solutions

NETWORK EQUIPMENT MANUFACTURERS

DESIGN AND VERIFICATION FROM DEVELOPMENT TO DEPLOYMENT

BE AGILE. YOUR WAY.

EXFO

THE FUTURE OF THE LAB IS HERE



Video, cloud computing and other new bandwidth-intensive applications are forcing operators to rapidly adapt and increase core and metro network capacity. At the same time, network equipment manufacturers (NEMs) are continuously enhancing their 40G/100G cross-connect offering to ensure that it is able to carry, switch and terminate all rate services in line with proper bandwidth usage without compromising their quality.

BUT, TOUGH CHALLENGES AWAIT

- › Tedious manual testing
- › Lack of efficiency and inaccurate results
- › Inability to test remotely
- › Inability to run simultaneous tests

FROM DEVELOPMENT TO DEPLOYMENT, WE HAVE THE ANSWER

EXFO brings innovative and multiservice converged networks testing solutions for 100G, 200G, 400G and beyond, addressing the needs of NEMs around the globe with regard to design, verification, and manufacturing. Accelerate your time-to-market and save costs with EXFO's innovative solutions.

NEW! Our agile and revolutionary lab solution includes the LTB-8—a highly scalable and compact platform featuring the industry's best 100G port density and hot-swap capabilities for no downtime or interruption in tests and greatly improved efficiency, the FTBx-88200NGE Power Blazer 100G Multiservice Test Module—the industry's first solution offering integrated CFP4 and QSFP+/QSFP28 interfaces, and EXFO Multilink—the industry's unique multi-user, multimodule and multiplatform lab test management system. A full range of new optical instruments with improved performances, including power meters, variable attenuators, switches and couplers.

Fully customized testing solutions to fit NEMs' needs:

- › Advanced testing applications for design, verification and manufacturing cycles
- › Port density with complete multi-user testing support for shared resources for optimized testing
- › Simplified graphical user interface for higher productivity and greater accessibility
- › Open architecture with complete automation and remote management for reliable, efficient and comprehensive testing
- › Modular solutions: fully configurable with software options
- › Multirate and multiservice offerings for 100G/400G and beyond

WHAT DOES THIS MEAN FOR NEMs?

Stability: Repeatable and accurate test results



Automation: Reduced human intervention



Increased quality of experience (QoE)/quality of service (QoS)/customer satisfaction/revenue



Accelerated testing process and time-to-market



OPEX savings, CAPEX reduction and protected investments





EXFO'S WIDE RANGE OF SOLUTIONS FOR HIGH-SPEED TRANSMISSION AND AUTOMATION MANUFACTURING

DISCOVER SCALABLE SOLUTIONS THAT MEET NETWORK EQUIPMENT MANUFACTURERS' TESTING NEEDS.

10G, 40G AND 100G SYSTEM VERIFICATION

COMPREHENSIVE MULTI-APPLICATION SUPPORT

Once various network elements have been integrated into a complete system, NEMs must test their performance and interactions to validate that the complete system complies with relevant standards and is able to perform reliably under various operating conditions. Occasionally, these tests are also performed for customer demonstrations, or system acceptance prior to delivery.

The biggest challenges for NEMs stem from the multiple services needing to be supported, the variety of tests to be performed, and the almost infinite number of system configurations that must be created to emulate "real" customer systems. As a result, the required testing tools must be able to cover a broad range of applications while offering proven flexibility.

Some of the typical tests or functions that may be required at this stage include OSNR measurement, amplifier loading, noise insertion, service disruption, and BERT.

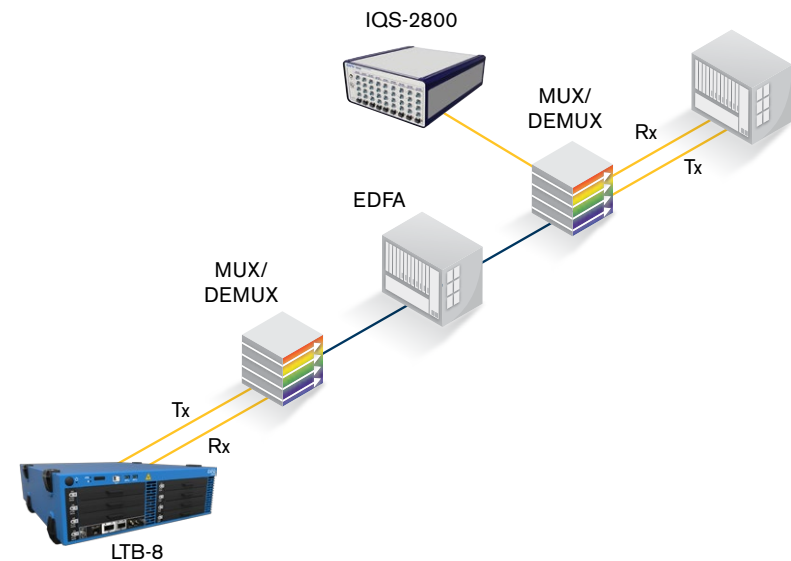

THE SOLUTION

FTBx-5245	FTBx-9600	IQS-88100NGE
IQS-2800	FTBx-3500	FTB/IQS-85100G
FLS-2800	FTBx-9150/9160	FTBx-1750
IQS-8830NGE	MXS-9100	FTBx-88200NGE
LTB-8	FTBx-8870/8880	

OPTICAL TRANSCEIVER TESTING

ERROR-FREE TRANSMISSION

Optical transceivers, which are devices that include both a transmitter and a receiver in a single package, are now widely used in 1G-to-100G optical networks. Pluggable transceivers come in various form factors tailored to different applications and data rates. Some of the most common form factors are SFP+, XFP, CFP, CFP2, CFP4 and QSFP28. These transceivers must comply with specifications and requirements of multiple standards, in addition to recommendations and multisource agreements (MSAs). In addition, manufacturers must perform extensive tests during the manufacturing process in order to guarantee their compliance. Typical tests performed on transceivers include central wavelength, in the case of fixed transmitters, and wavelength range, in the case of tunable transceivers with output power and receiver sensitivity.

NEMs who are using these transceivers may want to perform a subset of the tests during incoming inspection in order to verify their compliance with standards and MSAs prior to integration of the devices in their systems.

THE SOLUTION

FTBx-1750	IQS-88100NGE	FTBx-9150/9160
IQS-8830NGE	FTBX-5245	FTBx-3500
FTB-88100NGE	FTBx-88200NGE	pB100A4
LTB-8	LTK-1	FTBx-8870/8880

Typical Setup for QSFP28 Transceiver Tests

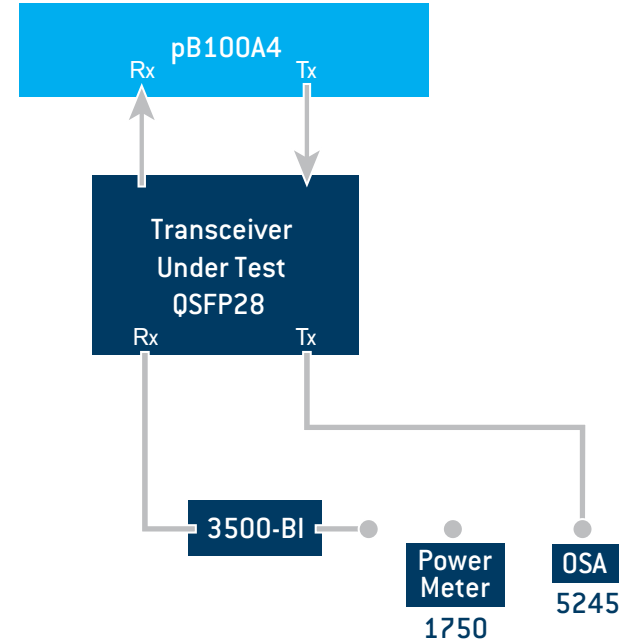

MANUFACTURING AUTOMATION

DELIVERING DURABLE PERFORMANCE

For improved manufacturing yields and lower production costs, automation of procedures and testing of multiple devices under test (DUT) have become a necessity for NEMs. Such automation enables all testing to be performed faster and more effectively with reduced risk of error. The ability to switch between network elements, DUTs and test instruments is critical to optimizing system automation.

Parallel testing of multiple DUTs, all requiring multiple tests and sequencing, can be easily performed using protocol and data-rate-independent MXS-9100 matrix switches. Automation requires remote-control capabilities, including Telnet, SCPI, LabVIEW, GPIB and TCL libraries, which are fully supported by all EXFO products and well integrated into the LTB-8 platform.

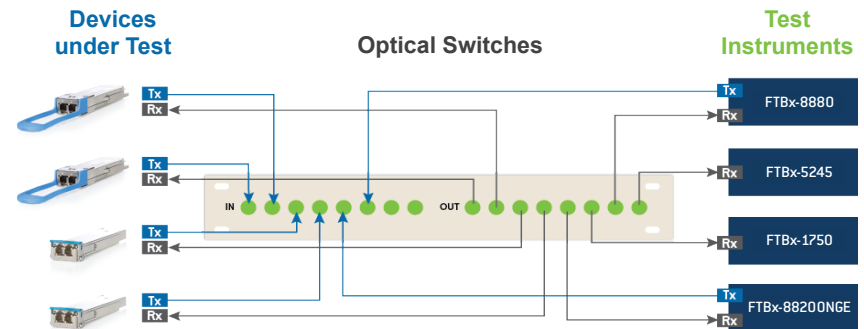

THE SOLUTION

LTB-8 (including IVI drivers, TCL libraries, Telnet services (remote control via Ethernet or GPIB))

FTBx-9150/9160

MXS-9100

Remote Toolbox

100G/200G/400G COHERENT SYSTEMS

TRANSMITTER TESTING AND OPTIMIZATION

Coherent transmitter testing and optimization in lab and manufacturing is critical in order to achieve the system performances expected with such high-speed transmission technology. One of the inherent challenges of such testing and optimization is that most transmitter problems can only be seen with a highly accurate modulation analyzer providing distortion-free signal recovery. This is all the more true in the case of new Nyquist filtering or raised cosine shaping applied to 200G and 400G signals.

There are over a dozen different adjustment points in a coherent transmitter and each of them can have a serious impact on transmission quality. For this reason, signal parameters such as IQ imbalance, IQ offset, skew and BER have to be accurately tested. However, these measurements involve complex calculations. In addition, deep knowledge of transmitter design is often required for proper evaluation the results analysis.

EXFO's expertise has been integrated into both the PSO-200 Optical Modulation Analyzer and the FTBx-5245 Optical Spectrum Analyzers to provide simple, accurate and reliable instruments with the features required by research and development (R&D) engineers, as well as the simplicity and integration required for manufacturing.

THE SOLUTION

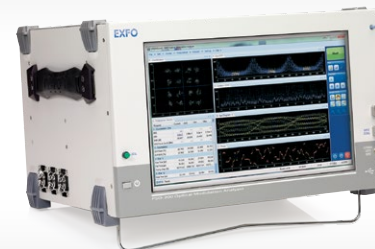

◀ PSO-200

FTBx-5245 ▶



MULTISERVICE FIELD TESTING

DEPLOYMENT, VALIDATION AND TROUBLESHOOTING

To meet the challenge of supporting the ever-growing demand for IP services consuming huge amounts of bandwidth, system manufacturers are continually investing in next-generation packet-based network elements capable of adapting to a wide range of client services and scaling to higher bandwidths while reducing costs and optimizing bandwidth management.

The network is becoming more and more complex, with multiple technologies such as Ethernet, Fibre Channel, SONET/SDH and optical transport network (OTN) combined within the same network. For this reason, it is crucial to validate and test all the different client ports supported by the network card, because these signals will be aggregated into OTN at different levels in the network and may cause some issues. This reinforces the need for NEMs to characterize each signal, perform interoperability tests, and ensure that all mapping are performed correctly.

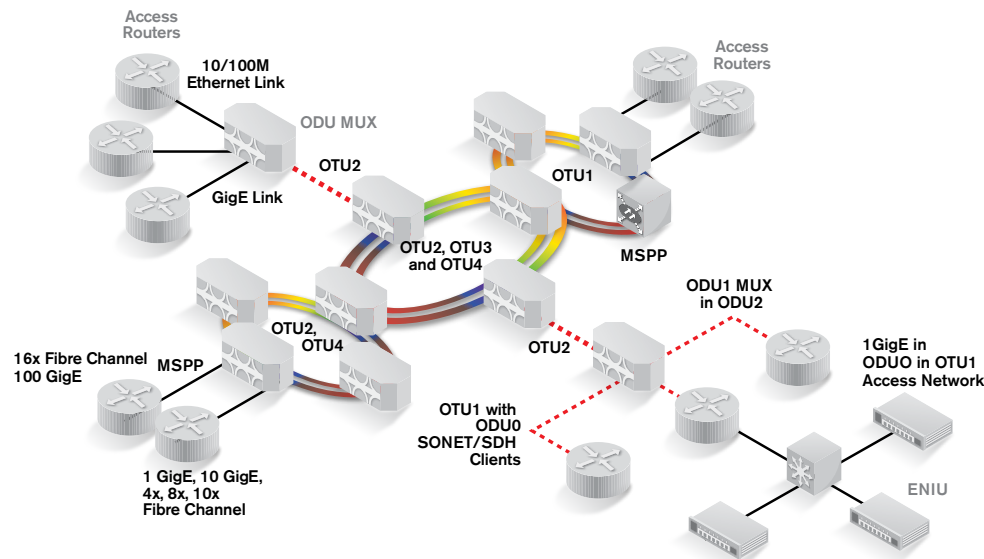

THE SOLUTION

10M-to-100G solution with Ethernet, Fibre Channel, SONET/SDH and OTN support.



CFP/QSFP VALIDATION

FLEXIBLE AND FUTURE-PROOF COVERAGE

NEMs are now including 100G LR4 C form-factor pluggables (CFPs), 100 LR4 CFP2s and CFP4s with all shipments of high-speed interface network cards. This is being done for two key reasons, the first being that they need to optimize and characterize the full end-to-end path for optimal transmission quality. In addition, because CFPs have an insertion factor limitation where multiple insertions can degrade the quality of the signal through the electrical interface, testing the specific card with a CFP (sold together in a single package) minimizes the impact on the electrical connector integrity. This actually forces NEMs to qualify and validate multiple CFPs, CFP2s and CFP4s in order to discover the optimal devices.

Laser status and per-lane power and frequency offset validation are some of the key tests that NEMs will be performing on the CFPs. MDIO read/write is another essential tool that NEMs will be using to configure and test CFPs. Advanced CFP signal conditioning is used to quickly identify signal integrity issues related to the electrical path towards the CFP.

In combination with iOptics on the FTB-88200NGE or the CFP Health Check solution on the IQS-85100G or IQS-88100NGE, EXFO delivers the ability to validate CFP, CFP2 and CFP4 transceivers, as well as QSFP/QSFP+/QSFP28 transceivers for advanced validation in data centers and web-scale IT applications.

Each one of these new transceivers receives 4 CAUI-4 lanes in the electrical interface which are directly converted into 4 x 25G optical lanes. These transceivers are all interoperable as long as their optical characteristics are compatible: SMF versus MMF, wavelength, number of lambdas, power level sensitivity. It's worth mentioning that for long reach applications, the most commonly used optical interface is the LC connector; for short reach applications, the most commonly used interface is the MPO (or MPT) connector.

XFP/SFP/SFP+ were single-wavelength devices, whereas CFPs are multiwavelength devices requiring wavelength-specific power meters only, and thereby require the use of optical channel analyzers. In addition, the longer reaches inherent to CFPs (up to 10 km for LR4) make meeting the loss budget more challenging than ever. All these trends call for CFP power measurements at the network element, where the client-side signals are converted to line-side signals. The FTB-5230S-OCA Optical Channel Analyzer is the ideal solution for this, because it features built-in configurations for 40GBase-LR4 and 100GBase-LR4/LR10 CFPs, thus ensuring quick and reliable power measurements at the touch of a button.

THE SOLUTION

iOptics



◀ FTBx-88200NGE
POWER BLAZER



FTB-5230S-OCA ▶
◀ FTB/IQS-85100G
PACKET BLAZER



◀ IQS-88100NGE
POWER BLAZER

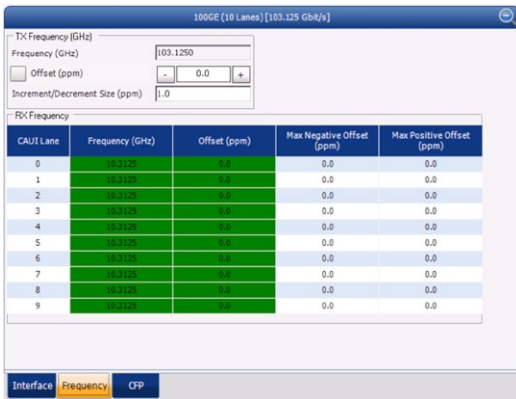

**FTBx-88200NGE
POWER BLAZER**

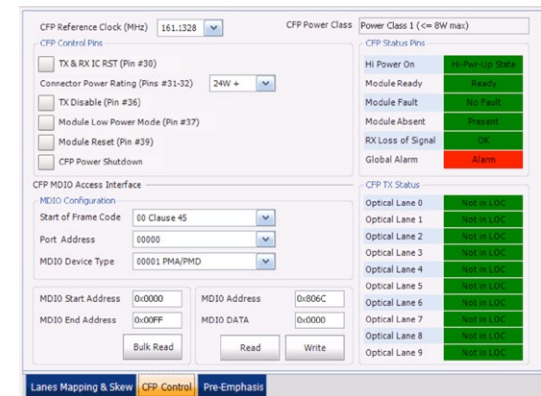
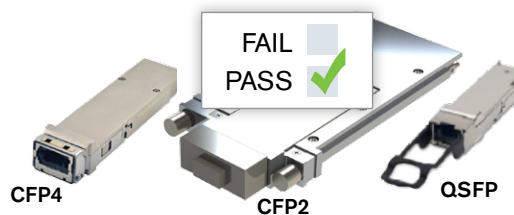
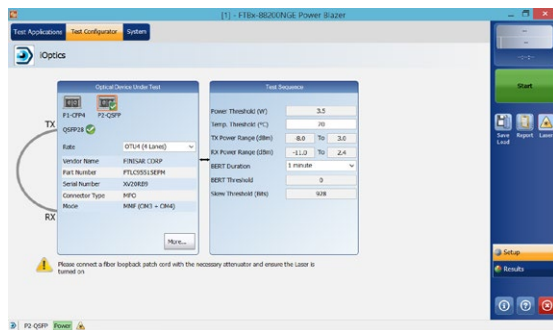
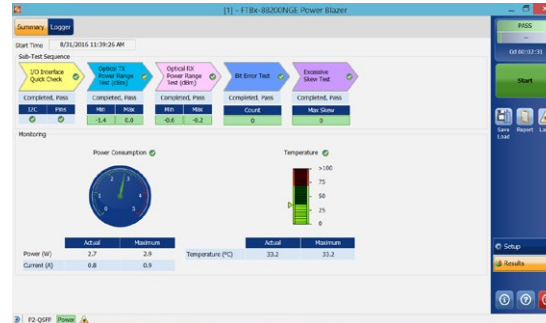
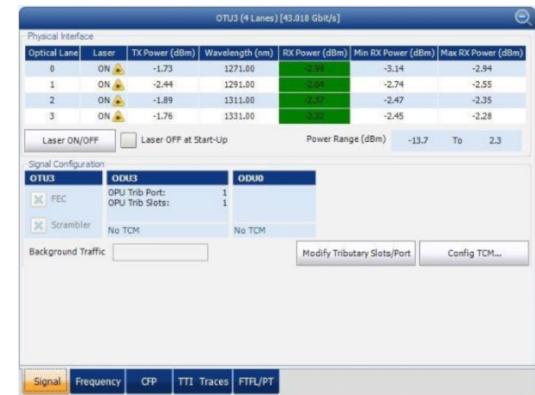

MUXPONDER TESTING

BREAKTHROUGH-LEVEL QUALIFICATION

NEMs have been releasing new muxponders in order to meet the challenge of supporting the ever-growing demand for Internet protocol (IP) services consuming huge amounts of bandwidth. Meanwhile, system manufacturers are continually investing in next-generation packet-based network elements capable of adapting to a wide range of client services and scaling to higher bandwidths while reducing costs and optimizing bandwidth management.

These new muxponders can aggregate multiple signals such as SONET/SDH and FC—in addition to Ethernet into OTN, which now provides enhanced containers specifically designed to carry the signals in an optimized manner. However, this also introduces a degree of complexity and new challenges to qualification of these new devices.

The complexity stems from the fact that NEMs have to test multiple client signals, each of which requires different timings and rates. All synchronization and mapping into OTN must be tested, with complete OTN mapping/demapping and OTN multiplexing validation also being part of the key challenges.

EXFO Multilink is a multi-user, web-based interface that uniquely enables remote access and control of multiple modules for multiple users on multiple ports and multiple platforms. It offers the industry's only truly integrated platform, server and controller for multi-user administration and management. EXFO Multilink delivers asset management, analytics and reporting of results as well as enabling EXFO TFv, FTB Anywhere floating licenses and FTB OnDemand time-based licenses.

THE SOLUTION

ODU Mux with Ethernet, pattern and SONET/SDH support



**FTBx-88200NGE
POWER BLAZER**



**IQS-88100NGE
POWER BLAZER**



**FTB/IQS-85100G
PACKET BLAZER**



The new line card supports many different protocols and data rates, and can be reconfigured in service to address the client's changing requirements. The following diagram shows how to test the multiplexing and demultiplexing function of a 100 Gbit OTN muxponder line card.

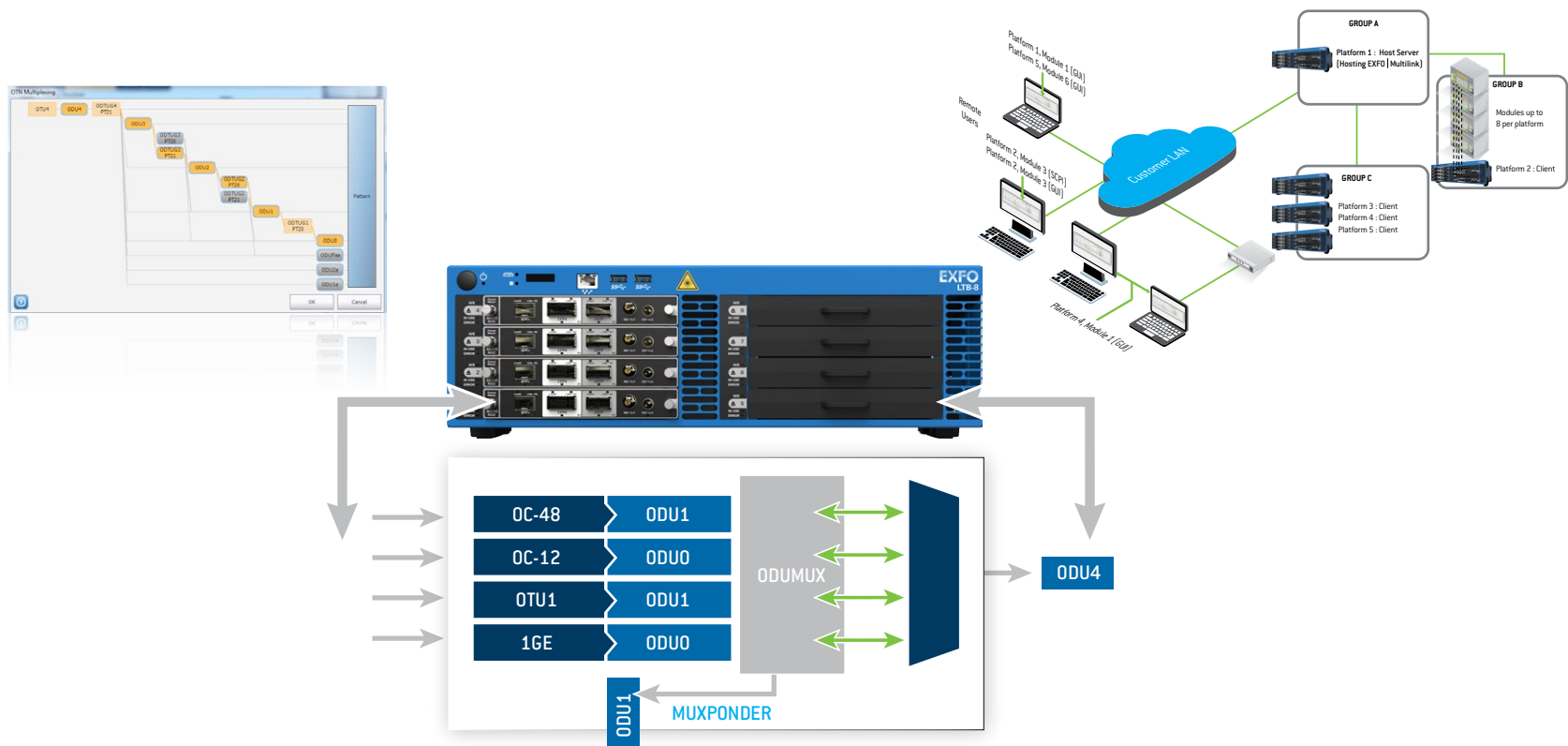

MULTICHANNEL OTN

VALIDATION OF UP TO 80 CHANNELS SIMULTANEOUSLY

In today's core network market, an increasing number of network operators are forced to deploy high-speed OTN links in response to increased demand for higher bandwidth. OTN technology offers efficient traffic grooming and optimal granularity through virtual containers such as ODU0, which in turn offer ideal support for packet-based services such as Ethernet and Fibre Channel. OTN transport of TDM traffic, for example SONET or SDH, offers a protection-switching mechanism that switches traffic from the working path to the protection path in the event of failures. Service providers and network operators need to identify, analyze and fix issues on an OTN network at the channel/tributary level making this multichannel OTN application a valuable and essential tool at all phases of a project.

The multichannel OTN application supports single stage multiplexing. The multichannel OTN application offers the possibility of decoupling the Tx tributary slot/channel assignment from the Rx tributary slot/channel assignment and the possibility of introducing TCM (tandem connection monitoring) and FTFL/PT (fault type and fault location/payload types) at a channel level, as per the user selection. EXFO's multichannel OTN feature enables the validation of up to 80 channels simultaneously.

THE SOLUTION



LTB-8 PLATFORM ►
◀ FTBx-88200NGE
POWER BLAZER



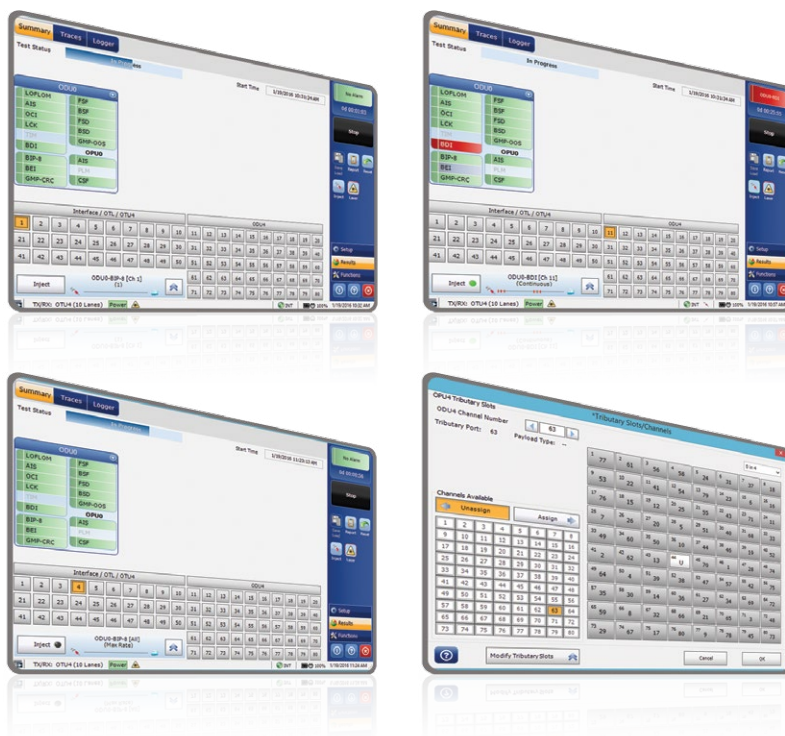

MULTIPLEXING	NUMBER OF CHANNELS
OTU4/ODU4/ODU0	80
OTU4/ODU4/ODU1	40
OTU4/ODU4/ODU2	10
OTU4/ODU4/ODU3	2

From a physical configuration point of view, this interoperability test may be set in 3 different ways:

Scenario 1:

The test equipment (FTBx-88200NGE) directly connected to the terminating NE (DUT)



Scenario 2:

Both the test equipment and the DUT connected to the network



Scenario 3:

Multiple DUT's connected to the network with a single test equipment unit generating the stimulus. In the following example, the test equipment is connected to the network via an OTU4 link but monitoring the interoperability of multiple DUT's via OTU2 links.

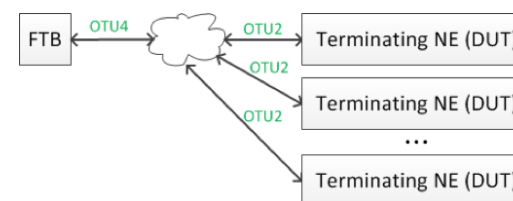

ETHERNET OVER OTN

UP TO 100G AND BEYOND

NEMs have now enhanced their transponder algorithm for easy transport of high-speed Ethernet signals towards packet optical transport in the OTN network, thereby extending reach. However, the transport of 40GE or 100GE clients over an OTN network brings with it certain challenges, as described below.

The integrity of the entire client signal needs to be preserved without any loss, and in some cases the signal may need to be compressed to ensure that it is transported correctly. The transponder coding algorithm is used to transcode the client signal (in this case Ethernet) to fit the size of the OTN payload. The mapping of 40GE into OTU3 requires a two-stage coding scheme in order to adapt the Ethernet traffic in the OTU3 payload. This is not the case for 100GE into OTU4, given that the OTU4 payload is able to easily transport Ethernet traffic. To align the synchronization, the generic mapping procedure (GMP) is used to ensure the correct timing needed to maintain the client signal.

The entire Ethernet-over-OTN (EoOTN) process needs to be validated in terms of where the Ethernet and OTN layers will need to be tested, thus ensuring the integrity of the entire signal during the mapping process, and that no Ethernet frames are dropped or corrupted.

The line side of the network will also need to be validated. Depending on the network application, this may consist of a simple OTN. However, most of the time the line side employs complex modulation requiring the use of an advanced optical test tool that can analyze the modulation to ensure that no signal degradation is preventing the Ethernet traffic from transiting without any loss.

EXFO's Multilink multi-user, web-based interface uniquely enables remote access and control of multiple modules for multiple users on multiple ports and multiple platforms. It offers the industry's only truly integrated platform, server and controller for multi-user administration and management. EXFO Multilink delivers asset management, analytics and reporting of results as well as enabling EXFO TFv, FTB Anywhere floating licenses and FTB OnDemand time-based licenses.

THE SOLUTION

EoOTN option allowing for insertion of 100GE into OTN, and 40GE into OTN (which requires transcoding). The EXFO EoOTN provides testing functionalities for Ethernet mapping, transcoding, and the OTN.



EXFO | MULTILINK

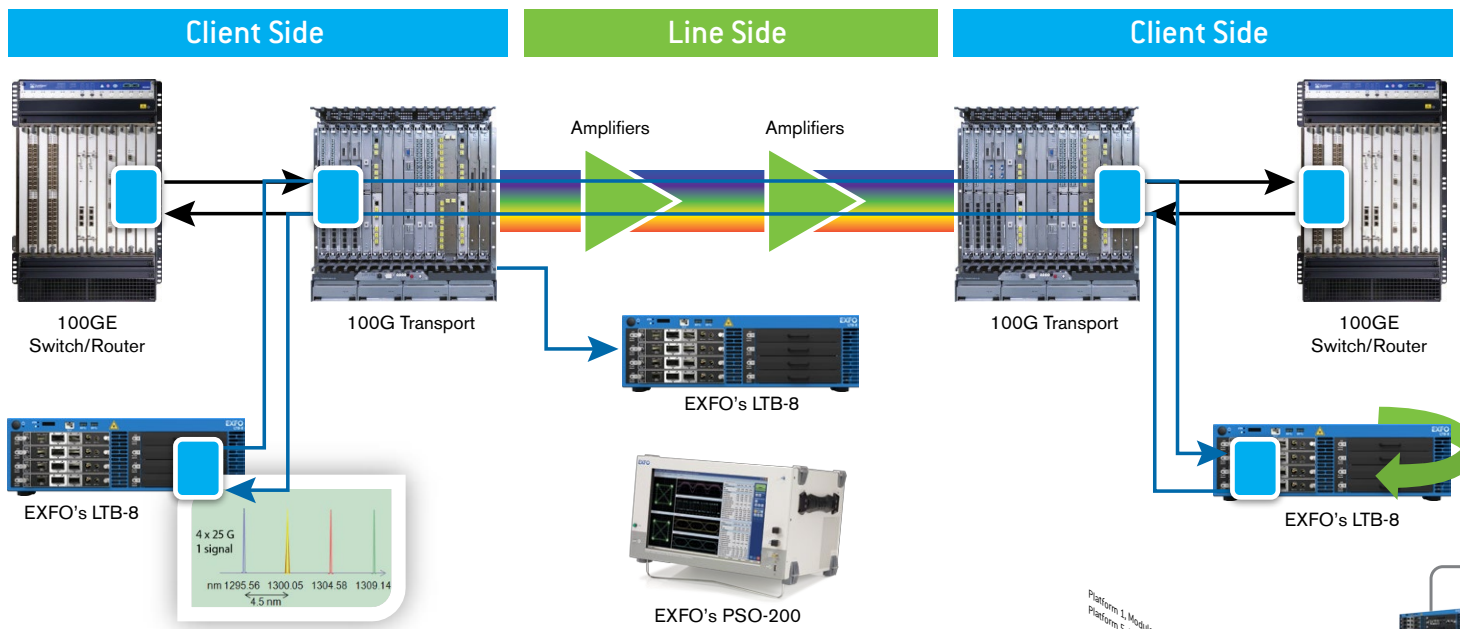

- Client Tests**
- CFP/CFP2 testing
 - CFP4/QSFP28 testing
 - Per λ Tx/Rx power
 - Per-lane frequency and offset
 - 100GE and OTU4 BERT
 - EoOTN
 - Y.1564 and KPIs validation
 - RFC 2544
 - iSAM
 - RFC 6349

- Line-WDM Tests**
- Chromatic dispersion
 - Polarization mode dispersion
 - OSNR-100G coherent
 - Signal impairments and severity assessment (WDM Investigator)
 - Eye diagrams, constellation diagram
 - Error vector magnitude (EVM) and time-resolved EVM

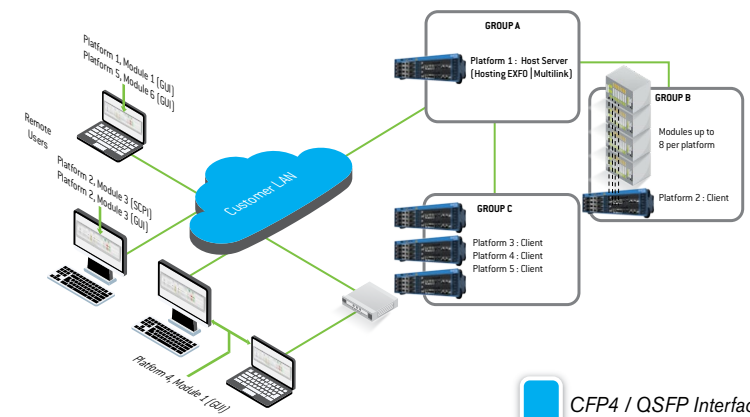

CFP4 / QSFP Interfaces



NEMs PRODUCT MATRIX BY APPLICATION

APPLICATIONS	Platforms																												
	LTB-8	IOS-600	IOS-1700	IOS-2150	IOS-2800	IOS-3150	IOS-5240S/BP	FTB-5230S-OCA	IOS-9100/9100B	IOS-9600	FTBx-1750	FTBx-3500	FTBx-5245	FTBx-9150/9160	FTBx-9600	pB100A4	LTK-1	FLS-2800	FVA-3800	MXS-9100	PSO-200	FTBx-88200NGE	FTB/IOS-85100G	IOS-88100NGE	FTBx-8870/8880	IOS-8830NGE	Remote Toolbox	EXFO Multilink	
System Verification	•	•	•	•	•	•	•	•	•	•	•	•	•	•	•	•	•	•	•	•	•	•	•	•	•	•	•	•	•
Optical Transceiver Testing	•	•	•			•	•		•		•	•	•	•		•	•			•			•	•	•	•	•		•
Manufacturing Automation	•	•	•		•	•	•		•	•	•	•	•	•	•	•	•			•	•		•		•	•	•	•	•
100G/200G/400G Coherent Transmitter Testing		•	•		•						•						•		•			•							
Multiservice Testing	•	•	•			•	•		•		•	•	•	•			•			•			•		•	•	•		
CFP/CFP2 Validation		•				•	•	•				•	•			•	•			•				•	•			•	•
CFP4/QSFP28 Validation	•															•							•					•	•
Muxponder Testing	•	•																					•	•	•			•	•
Transponder Ethernet over OTN for 100G+	•	•																					•	•	•			•	•

PRODUCT OVERVIEW

OPTICAL COMMUNICATION ANALYSIS

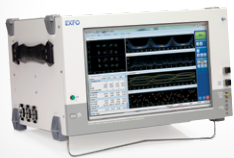

PSO-200–Optical Modulation Analyzer

Complete characterization of phase-modulated signals at 100 Gbit/s and beyond.

OPTICAL POWER METERS



FTBx-1750–High-Performance Power Meter

Delivers high performance in an R&D environment, or in an active/passive component manufacturing setup.

OPTICAL SPECTRUM ANALYZER



FTBx-5245–Optical Spectrum Analyzer

Featuring unique Pol-Mux OSNR measurement technology, our highly accurate and easy-to-use intelligent OSAs are designed for current and next-generation networks.

OPTICAL SWITCHES AND UTILITY MODULES



FTBx-9160–MEMs Optical Switch

Delivers durable performance in a compact package, with highly accurate and repeatable fiber-to-fiber switching for singlemode 1 x N configurations up to 1 x 32.

LIGHT SOURCES



FLS-2800–ITLA Tunable Light Source

Benchtop, continuous-wave (CW), tunable laser with a high-power output, narrow 100 kHz line width, and 10 pm resolution tunability over the C and/or L bands.

MXS-9100–MEMS Matrix Optical Switch



An all-optical cross-connect technology optimized for EXFO systems and software control, providing fast protection switching at the fiber layer, automation of test sequences and instrument-grade performance.

ETHERNET OTN ANALYZERS



IQS-88100NGE/88100G Power Blazer– High-Speed Multiservice Test module

Turnkey test solution for installing, validating and troubleshooting networks up to 100G at the central office and in manufacturing environments.



IQS-8830NGE Power Blazer– 10G Multiservice Test Module

A comprehensive test modules suite for turn-up, circuit validation and troubleshooting of Ethernet, SONET/SDH, OTN, Fibre Channel and SyncE/1588 PTP services up to 10G.



IQS-85100G Packet Blazer– 40G/100G Multiservice Test Module

Integrated multiservice testing solution for efficient, cost-effective and comprehensive layer 1/2/3 testing processes that validate performance against real-world scenarios.



FTBx-8870/8880 Power Blazer Series

Turnkey compact field-test solution for deploying and troubleshooting networks up to 100G.



FTBx-88200NGE Power Blazer– 100G Multiservice Test Module

Next-generation, 100G, advanced multiservice test solution with CFP4 and QSFP28 interfaces.



FTB-85100G Packet Blazer– 100G/40G Ethernet and OTN Test Module

Streamlines lab testing, field trials and early deployments. Plus, the newly enhanced 40G/100G test capabilities enable NEMs and carriers to qualify OTN muxponders.



LTB-8–Rackmount Platform

A powerful, scalable, 8-slot rackmount platform designed for advanced lab applications.

OPTICAL VARIABLE ATTENUATORS



FTBx-3500-Variable Attenuator

Ideal for transceiver testing and system verification in demanding 24/7 production environments.

QUAD 24G TO 30G PRBS GENERATOR AND BERT



Fully integrated quad 24G to 30G PRBS generator and BERT ideal for CFP2, CFP4, QSFP28 and active cable testing

- › PRBS generators 231-1, 223-1, 215-1, 29-1, 27-1, Square wave, SSPR (OIF-CEI-03.0)
- › Support bit-error-rates up to $10e^{-2}$
- › Four independent CDR
- › 4x10G and Rx eye diagram monitoring (software enabled options)



LTK-1-Benchtop Optical Kits

Compact and flexible test kits in new LTB-1 lab benchtop platform.

**ACCELERATE YOUR TIME-TO-MARKET AND SAVE
COSTS WITH EXFO'S INNOVATIVE SOLUTIONS**

www.EXFO.com/NEMs
