

OTN (G.709) Reference Guide

Your insight into the optical transport network

4th Edition

EXFO

About EXFO

EXFO is among the leading providers of next-generation test and service assurance solutions for wireless and wireline network operators and equipment manufacturers in the global telecommunications industry. The company offers innovative solutions for the development, installation, management and maintenance of converged, IP fixed and mobile networks – from the core to the edge. Key technologies supported include 3G, 4G/LTE, IMS, Ethernet, OTN, FTTx, and various optical technologies (accounting for an estimated 35% of the portable fiber-optic test market). EXFO has a staff of approximately 1600 people in 25 countries, supporting more than 2000 telecom customers worldwide.

About the Author

Mai Abou-Shaban, Product Specialist, Transport and Datacom Business Unit, brings to EXFO her extensive experience in optical transport networks on addition to working with major telecom accounts in Americas, EMEA and Asia. She holds a Bachelor degree in Electrical Engineering from Concordia University, Montreal, QC. Mai has eleven years of experience working for public and privately held companies in the areas of systems engineering, product marketing as well as in sales support.

Table of Contents

1. Introduction	3	6. Overclocked Optical Transport Network	37
2. Optical Transport Network (OTN) Layers	5	6.1 OTU2e—10GBASE-R Signal Mapping into OPU2e.....	38
3. G.709 Interfaces and Rates	9	6.2 OTU1e—10GBASE-R Signal Mapping into OPU1e.....	39
4. OTU Frame Structure and Overhead	11	6.3 GFP-F Mapping of 10GBASE-R into OPU2	39
4.1 Framing.....	11	6.4 ODU2 Signal Mapping into ODU3e.....	39
4.2 Overhead.....	13	7. Testing Optical Transport Network Elements	40
4.2.1 Optical Channel Transport Unit (OTU) Overhead	13	7.1 Interface Specifications Test	41
4.2.2 Optical Channel Data Unit (ODU) Overhead.....	16	7.2 Response Test	42
4.2.3 Optical Channel Payload Unit (OPU) Overhead.....	24	7.3 Conformance and Interoperability Test.....	43
4.3 OTU Forward Error Correction (FEC)	28	7.4 Client Signal Mapping Test.....	43
5. OTN Multiplexing.....	31	7.5 Appropriate FEC Behavior Test.....	44
5.1 ODUk Multiplexing.....	31	7.6 ODU1 to ODU2 Multiplexing.....	45
5.2 ODU0.....	32	7.7 ODU0 to OTU2 Multiplexing.....	45
5.3 ODUFlex.....	35	7.8 OTN as a Service	46
		7.8.1 Today's OTN Structure.....	48
		8. Conclusion	50
		9. Acronyms	52

1

Introduction



1. Introduction

In today's telecom/datacom environment, network operators are forced to integrate their networks in order to reduce operational expenses (OPEX) and eliminate the additional capital expenditures (CAPEX) generated by multiple parallel networks. Every network operator is therefore attempting to provide the greatest number of services on the leanest possible infrastructure to drive faster returns on investments. For instance, traditional telecom carriers and service providers are now considering deploying new technologies to help meet new market demands and challenges. Examples of such technological changes include implementing broadband access—both wired (e.g., xDSL, FTTx) and wireless (IEEE 802.11); as well as migrating from circuit-switched voice services to voice-over-IP (VoIP) and from ATM- and FDDI-based solutions to gigabit Ethernet. In addition, there is the added pressure of growing demand for high-capacity, fixed-bandwidth services and the challenge of fulfilling all their requirements.

In response to such changes, the ITU-T developed a set of standards to meet these emerging needs. ITU-T recommendation G.709, *Interface for the optical transport network (OTN)*, is among the latest of these standards, and its aim is to address the transmission requirements of today's wide range of services; namely, it was developed to assist in network evolution to higher bandwidth and improve network performance. Many of the notions in ITU-T G.709 are similar to those in SONET/SDH; e.g., layered structure, in-service performance monitoring, protection and other management functions. However, some key elements have been added to continue the cycle of improved performance and reduced cost. Among these key elements, the ITU-T G.709 provides a standardized way to manage the optical channels in the optical domain without the need to convert the optical signals to electrical signals, to apply a forward error correction (FEC) algorithm to improve transmission performance, to enable longer spans, and to scale at 100G rates.

Currently, the majority of OTN applications are running on dense wavelength-division multiplexing (DWDM) transport networks. However, products that support OTN standards to various degrees are already available and even more OTN-based product lines and feature sets are expected to hit the market in the very near future.

2

Optical Transport Network (OTN) Layers



2. Optical Transport Network (OTN) Layers

The optical transport hierarchy (OTH) is a new transport technology for optical transport networks (OTNs) developed by the ITU. It is based on the network architecture defined in various recommendations (e.g., G.872 on architecture; G.709 on frames and formats and G.798 on functions and processes). OTH combines electrical and optical multiplexing under a common framework. The electrical domain is structured in a hierarchical order, just like SONET/SDH, and the optical domain is based on DWDM multiplexing technology but with standardized interfaces and methods to manage the network. ITU-T recommendation G.872, *Architecture for the Optical Transport Network (OTN)*, defines two classes of OTN interfaces (see Figure 2.1- *laDI vs. lrDI interfaces*).

- > **OTN inter-domain interface (lrDI)**: This interface connects the networks of two operators, or the subnetworks of one or multiple vendors in the same operator domain. The lrDI interface is defined with 3R (reshape, regenerate and retime) processing at each end.
- > **OTN intra-domain interface (laDI)**: This interface connects networks within one operator and vendor domain.

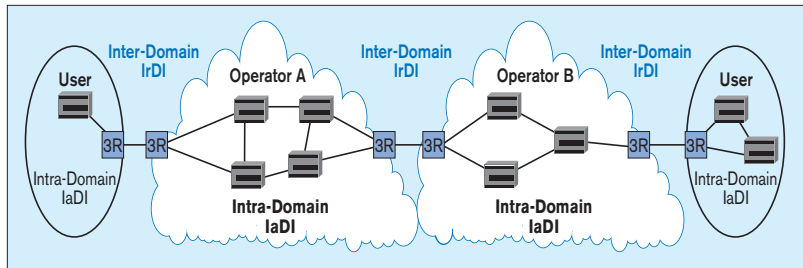

Figure 2.1 – laDI vs. lrDI Interfaces

The ITU G.872 recommendation also defines the optical network architecture based on the optical channel (OCh) carried over a specific wavelength. Different from that of legacy DWDM systems, the structure of this signal is standardized. The OTN architecture is composed of three layers, shown in *Figure 2.2 - OTN Layer Termination Points*, and constructed using the OCh with additional overheads.

- > **Optical channel (OCh)** – represents an end-to-end optical network connection with the encapsulated client signal in the G.709 frame structure.
- > **Optical multiplex section (OMS)** – refers to sections between optical multiplexers and demultiplexers.
- > **Optical transmission section (OTS)** – refers to sections between any network elements in the OTN, including amplifiers.

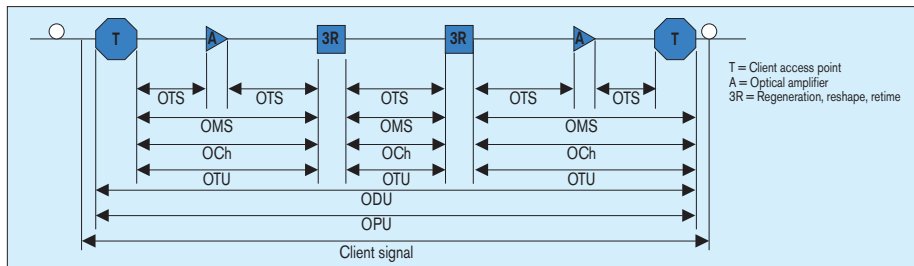

Figure 2.2 – OTN Layer Termination Points

The termination of the OTS, OMS and OCh layers is performed at the optical level of the OTN. The OCh payload consists of an electrical substructure, where the optical channel transport unit (OTU) is the highest multiplexing level. This layer is the digital layer—also known as the “digital wrapper”—which offers specific overhead to manage the OTN’s digital functions. The OTU also introduces a new dimension to optical networking by adding forward error correction (FEC) to the network elements, allowing operators to limit the number of required regenerators used in the network and in turn reduce cost.

The transport of a client signal in the OTN (shown in Figure 2.3 – Basic OTN Transport Structure) starts with the client signal (SONET/SDH, Ethernet, FC, ATM, GFP, etc.) being adapted at the optical channel payload unit (OPU) layer by adjusting the client signal rate to the OPU rate. The OPU overhead itself contains information to support the adaptation process of the client signal. Once adapted, the OPU is mapped into the optical channel data unit (ODU) with the necessary ODU overhead to ensure end-to-end supervision and tandem connection monitoring. Finally, the ODU is mapped into an OTU, which provides framing, as well as section monitoring and FEC.

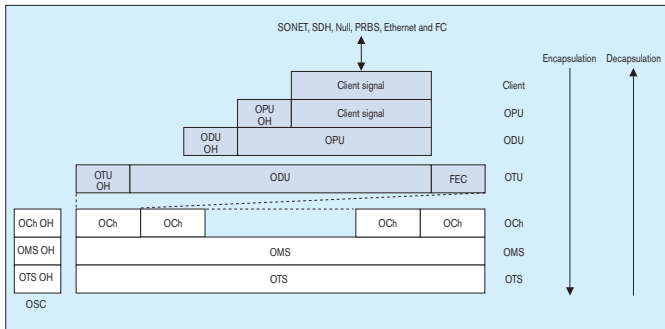

Figure 2.3 – Basic OTN Transport Structure

Each OTU_k ($k = 1, 2, 3, 4$) is transported using an optical channel (OCh) assigned to a specific wavelength of the ITU grid. Several channels can be mapped into the OMS layer and then transported via the OTS layer. The OCh, OMS and OTS layers each have their own overhead for management purposes at the optical level. The overhead of these optical layers is transported outside of the ITU grid in an out-of-band common optical supervisory channel (OSC). In addition, the OSC provides maintenance signals and management data at the different OTN layers.

3

G.709 interfaces and Rates



3. G.709 Interfaces and Rates

The ITU-T G.709 recommendation defines standard interfaces and rates based on the existing SONET/SDH rates, along with packet-based services including Ethernet and Fibre Channel. When taking into consideration the additional G.709 overhead and FEC information, the resulting interfaces operate at line rates roughly 7% higher than the corresponding SONET/SDH rates. *Table 3.1 – G.709 Defined Interfaces* lists the G.709 line rates and their corresponding SONET/SDH interfaces along with packet based services including Ethernet and Fiber Channel.

OTN Interface	Line Rate	Corresponding Service
ODU0 (virtual)	1.244 Gbit/s	Gig-E OC-3/STM-1 OC-12/STM-4
OTU1	2.666 Gbit/s	OC-48/STM-16
OTU2	10.709 Gbit/s	OC-192/STM-64 10 GigE LAN (using GFP-F)
OTU1e	11.0491 Gbit/s (without stuffing bits)	10 GigE LAN (direct mapping over OTN)
OTU2e	11.0957 Gbit/s (with stuffing bits)	10 GigE LAN (direct mapping over OTN)
OTU1f	11.27 Gbit/s (without stuffing bits)	10G Fibre Channel
OTU2f	11.3 Gbit/s (with stuffing bits)	10G Fibre Channel
OTU3	43.018 Gbit/s	OC-768/STM-256 40GE
OTU3e1	44.57 Gbit/s	4X ODU2e (uses 2.5G TS; total of 16)
OTU3e2	44.58 Gbit/s	4X ODU2e (uses 1.25G TS; total of 32)
OTU4	111.81 Gbit/s	100GE

Table 3.1 – G.709 Defined interface lists the G.709 line rates and their corresponding mapped client services.

4

OTU Frame Structure and Overhead



4. OTU Frame Structure and Overhead

Figure 4.1 - OTU Frame Structure illustrates the three parts that constitute the optical channel transport unit (OTU) frame:

- > Framing (frame alignment signal and multiframe alignment signal)
- > OTU, ODU, OPU overhead
- > OTU forward error correction

4.1. Framing

When transmitting serial blocks of data in an optical transport system, it is essential for the receiving equipment to identify the block boundaries. The ability to identify the starting point in the OTN is accomplished through the use of framing bytes, which are transmitted in every frame. The OTU framing structure is divided into two portions: frame alignment signal (FAS) and multiframe alignment signal (MFAS), shown in *Figure 4.2 – G.709 Frame Alignment*.

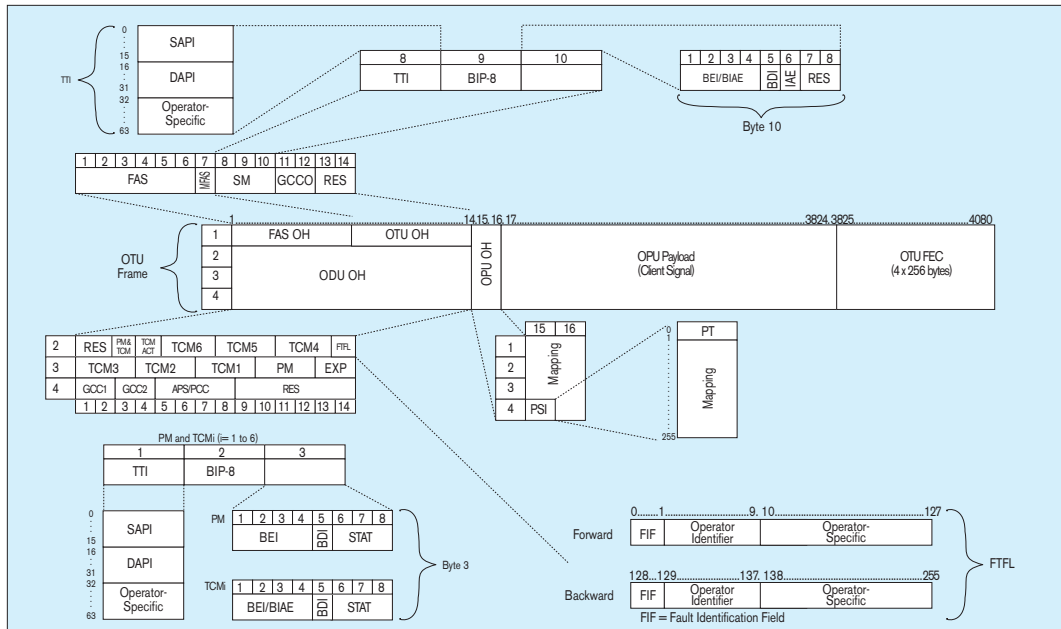

Figure 4.1 - OTN Frame Structure

- > **Frame alignment signal (FAS)** – uses the first six bytes in row 1, columns 1 to 6. As in SONET/SDH, G.709 uses FAS to provide framing for the entire signal and to identify out-of-frame (OOF) and loss-of-frame (LOF) conditions
- > **Multiframe alignment signal (MFAS)** – G.709 supports multiframe structure, in which some of the OTU and ODU overhead signals could span multiple OTU frames. Examples are the trail trace identifier (TTI) and tandem connection monitoring activation (TCM-ACT) overhead signals. A single MFAS byte is used to extend command and management functions over several frames. The MFAS byte is defined in row 1, column 7 of the G.709 frame and incremented for each OTU/ODU frame, providing a 256 multiframe structure.

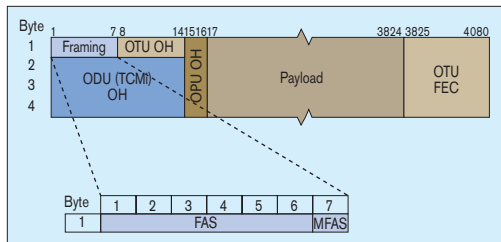

Figure 4.2 – G.709 Frame Alignment

4.2. Overhead

4.2.1. Optical Channel Transport Unit (OTU) Overhead

The OTU overhead is comprised of the SM, GCC0 and RES bytes, shown in *Figure 4.3 – OTU Overhead and SM Structure*.

- > **Section monitoring (SM)** bytes are used for the trail trace identifier (TTI), parity (BIP-8) as well as the backward error indicator (BEI), backward incoming alignment error (BIAE), backward defect indicator (BDI), and incoming alignment error (IAE).
- > *SM trail trace identifier (TTI)* is a one-byte overhead field defined to support 64-byte trace signals. TTI is used to identify a signal from the source to the destination within the network. The TTI contains the so-called access point identifiers (API) field, which is used to specify the source access point identifier (SAPI) and destination access point identifier (DAPI). The APIs contain information regarding the country of origin, network operator and administrative details.

- > *SM error bit-interleaved parity-8 (BIP-8)* is a one-byte error detection code signal. The OTUk BIP-8 is computed over the OPUk area of a specific frame and inserted in the OTUk BIP-8 overhead two frames later.
- > *SM backward defect indication (BDI)* is a single-bit signal defined to convey the signal fail status detected in the upstream direction.
- > *SM backward error indication and backward incoming alignment error (BEI/BIAE)* is a four-bit signal used to convey in the upstream direction the number of interleaved-bit blocks detected in error by the section monitoring BIP-8 code. It is also used to convey in the upstream direction an incoming alignment error (IAE) condition that is detected in the section monitoring IAE overhead.
- > **General communications channel (GCC0)** field, which resembles the data communications channel (DCC) in SONET/SDH, is currently undefined, but it will likely be used for functions such as network management or control plane signaling for a protocol like generic multiprotocol label switching (G-MPLS).
- > **Reserved (RES)** fields, found throughout the overhead, are set aside for future use.

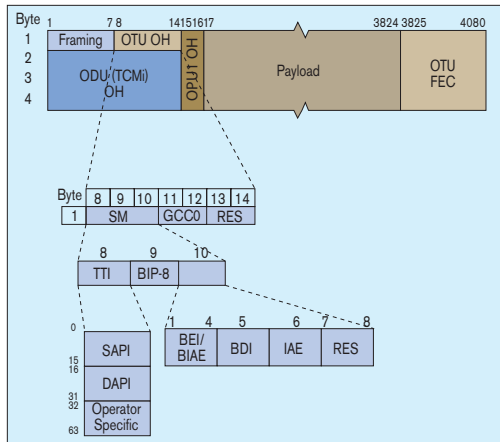

Figure 4.3 – OTU Overhead and SM Structure

Field	Definition	
Section monitoring (SM)	SM consists of the following bytes; TTI, BIP-8, BEI, BIAE, BDI and IAE	
	Trail trace identifier (TTI)	The 64-byte multiframe TTI signal is similar to the J0 byte in SONET/SDH.
	Bit-interleaved parity (BIP-8)	The BIP-8 value covers the OPU and client payload of the G.709 frame and its value is inserted in the BIP-8 field of the second frame following calculation.
	Backward defect indication (BDI)	When an AIS is sent in the downstream direction as a response to a signal fail indication (such as in the FTFL), the upstream direction response to continuity, connectivity and maintenance signals is a backward defect indication (BDI) signal. BDI is raised as an alarm when it has been received for five consecutive frames.
	Backward error indication (BEI)	The detection of a frame slip, which can occur at the OTU, generates an and backward incoming alignment error (IAE) in the downstream direction. The three-bit value alignment error (BIAE)
	STAT	These three bits indicate the presence of maintenance signals (AIS, OCI, TCMi, IAE).
General communication channel 0 (GCC0)	A clear channel used for transmission of information between OTU termination points.	
RES	Reserved bytes that are currently undefined in the standard.	

Table 4.1 – Summary of OTU Overhead Bytes

4.2.2. Optical Channel Data Unit Overhead

The optical channel data unit (ODU) overhead, shown in *Figure 4.4 - ODU Overhead and PM/TCMi Structure*, supports two classes of ODUk maintenance signals, reported using path monitoring overhead (PMOH) status (STAT) bits and tandem connection monitoring (TCM) STAT bits. Through either PMOH or TCM STAT bits, the following ODU conditions can be reported: alarm indication signal (ODUk-AIS), open connection indication (ODU-OCI), locked (ODUk-LCK), and generic AIS. In addition, the ODUk overhead supports automatic protection switching (APS) functionality. The ODUk overhead is broken into the following fields: RES, PM, TCMi, TCM ACT, FTL, EXP, GCC1/GCC2 and APS/PCC.

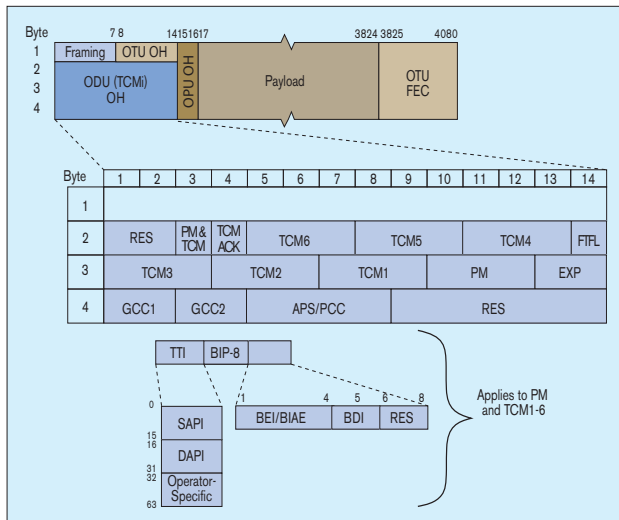

Figure 4.4 - ODU Overhead and PM/TCMi Structure

- > **Reserved (RES)** bytes are undefined and are set aside for future applications.
- > **Path monitoring (PM)** enables the monitoring of particular sections within the network as well as fault location in the network. The PM bytes are configured in row 3, columns 10 to 12, and contain subfields similar to the ones in SM including: TTI, BIP-8, BEI, BDI and Status (STAT) subfields.
 - > *PM trail trace identifier (TTI)* is a one-byte overhead field similar to the J0 byte in SONET/SDH. It is used to identify the signal from the source to the destination within the network. The TTI contains the so-called access point identifiers (API) field, which is used to specify the source access point identifier (SAPI) and destination access point identifier (DAPI). The APIs contain information regarding the country of origin, network operator and administrative details.
 - > *PM bit-interleaved parity (BIP-8)* is a one-byte field, which is used for error detection. The BIP-8 byte provides a bit-interleaved parity – eight-bit code computed over the whole OPU and inserted into the BIP-8 SM two frames later.
 - > *PM backward defect indication (BDI)* is a single bit, which conveys information regarding signal failure in the upstream direction.
 - > *PM backward error indication (BEI)* and backward incoming alignment error (BIAE) signals carry information on interleaved-bit blocks detected in error in the upstream direction. These fields are also used to convey incoming alignment errors (IAE) in the upstream direction.
 - > *PM status (STAT)* is a three-bit field used to indicate the presence of maintenance signals.
- > **Tandem connection monitoring (TCMi)** fields, which are part of the ODU overhead, define six ODU TCM sublayers. Each TCM sublayer contains a TTI, BIP-8, BEI/BIAE, BDI and STAT subfield associated with a TCMi level (i = 1 to 6).
- > **Tandem connection monitoring activation/deactivation (TCM ACT)** is a one-byte field located in row 2, column 4. TCM ACT is currently undefined in the standard.
- > **Fault type and fault location (FTFL)** is a one-byte field located in row 2, column 14 of the ODU overhead and is used to transport a fault type and fault location (FTFL) message, spread over a 256-byte multiframe for sending forward and backward path-level fault indications (shown in *Figure 4.5 – FTFL Field Structure*). The forward field is allocated to bytes 0 through 127 of the FTFL message. The backward field is allocated to bytes 128 through 255 of the FTFL message.

> **Experimental (EXP)** is a two-byte field located in row 3, columns 13 and 14 of the ODU overhead. The EXP field is not subject to standards and is available for network operators to support applications that may require additional ODU overhead.

> **General communication channels 1 and 2 (GCC1/GCC2)** are two fields of two bytes each, and they support general communication channels between any two network elements;

similar to the GCC0 field, except that they are available in the ODU overhead. GCC1 is located in row 4 and columns 1 and 2 and GCC2 is located in row 4, columns 3 and 4 of the ODU overhead.

> **Automatic protection switching and protection communication channel (APS/PCC)** is a four-byte signal defined in row 4, columns 5 to 8 of the ODU overhead. The APS/PCC field supports up to eight levels of nested APS/PCC signals, which are associated with dedicated-connection monitoring.

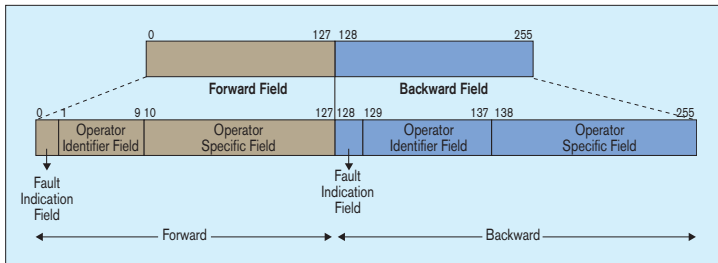

Figure 4.5 – FTFL Field Structure

Field	Definition	
Path monitoring	PM consists of the following bytes; TTI, BIP-8, BEI, BIAE, BDI and IAE.	
	Trail trace identifier (TTI)	The 64-byte multiframe TTI signal is similar to the J0 byte in SONET/SDH.
	Bit-interleaved parity (BIP-8)	The ODU PM contain a BIP-8 field that covers the OPU and customer payload of the G.709 frame. The BIP-8 values are inserted in the BIP-8 field of the frame following calculation.
	Backward defect indication (BDI)	The AIS — forwarded signal in the downstream direction — is sent as a response to a signal fail indication, such as in the FTFL or the incoming ODU-AIS. In the upstream direction, the response to continuity, connectivity and maintenance signals is a backward defect indication (BDI) signal indicated by a bit found in the PM and TCMi. BDI is raised as an alarm when it has been received for five consecutive frames.
	Backward error indication (BEI) and backward incoming alignment error (BIAE)	The AIS — forwarded signal in the downstream direction — is usually sent as a response to a signal fail indication, such as in the FTFL or the incoming ODU-AIS. In the upstream direction the response to continuity, connectivity and maintenance signals is a BDI signal indicated by a bit found in the PM and TCMi. BDI is raised as an alarm when it has been received for five consecutive frames.
	STAT	These three bits indicate the presence of maintenance signals (AIS, OCI, TCMi, IAE)

Table 4.2 – Summary of ODU Overhead Bytes (continued on page 19)

Tandem connection monitoring (TCM)	Six TCM sublayers are defined in the ODU overhead. Each TCM sublayer contains TTI, BIP-8, BEI/BIAE, BDI and STAT subfields.
Tandem connection monitoring activation/deactivation (TCM ACT)	One-byte field used for the activation and deactivation of the TCM fields. This field is currently undefined in the standard.
Fault type and fault location (FTFL)	Reporting communication channel field that is used to create a message for sending forward and backward path-level fault indications.
Experimental (EXP)	This field is not subject to standards and is available for network operator applications.
General communication channel 1 and 2 (GCC1/GCC2)	Clear channels used for transmission of information at the ODU layer; similar to the GCC0.
Automatic protection switching and protection communication channel (APS/PPC)	This field supports up to eight levels of nested APS/PCC signals, which are associated to a dedicated-connection monitoring level.
RES	Reserved bytes that are currently undefined in the standard.

Table 4.2 – Summary of ODU Overhead Bytes (continued)

- › **Tandem connection monitoring (TCM)** has been implemented in SONET/SDH networks to enable carriers to monitor the quality of the traffic across multiple networks. This has been achieved by breaking the path into a series of tandem paths, each owned and managed by individual network operators. Errors and defects along the path can be traced to a particular tandem path for fast and easy troubleshooting. *Figure 4.6 – Tandem Connection Monitoring* shows an example of a small network operator (operator B) that is leasing network resources from a larger network operator (operator A) rather than install its own networks. Operator A requires the ability to monitor the transmitted signal as it passes through operator B's network. Should a fault develop in the network, using tandem connection monitoring, operator A can quickly identify whether the fault is located in operator B's network, or further along the tandem path with another operator. In addition, different monitoring functions can be assigned to different connections. For example in *Figure 4.6 – Tandem Connection Monitoring (TCM)*, TCM1 is assigned to monitor the end-to-end quality of service (QoS), TCM2 is used by operator A to monitor their end-to-end QoS, and finally TCM3 is used for various domains and domain-interconnect monitoring.

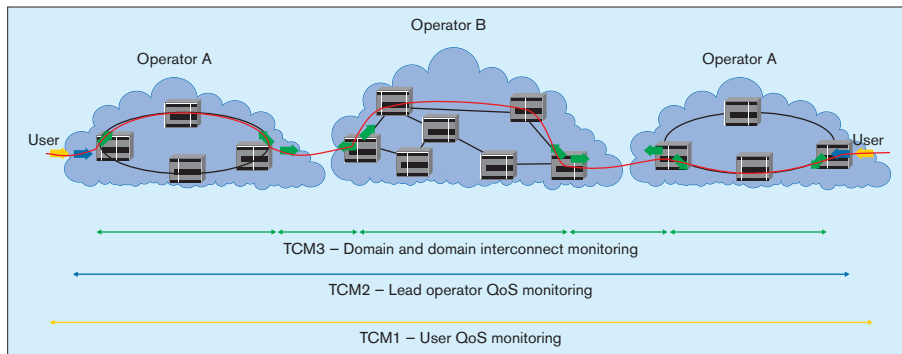

Figure 4.6 – Tandem Connection Monitoring (TCM)

In optical transport networks, each one of the six TCM_i fields has the same structure as the PM field, including the following subfields: TTI, BIP8, BDI, BEI, status bits, indicating the presence of incoming alignment error (IAE) or a maintenance signal (STAT). Optical transport networks support three TCM topologies, as shown in *Figure 4.7 – OTN Tandem Connection Monitoring (TCM) Topologies*. Figure 4.7a shows tandem connections C1-C2, B1-B2 and A1-A2 in nested configuration. Figure 4.7b shows tandem connections B1-B2 and B3-B4 in cascaded configuration. Finally, Figure 4.7c shows tandem connections B1-B2 and C1-C2 in overlapping configuration.

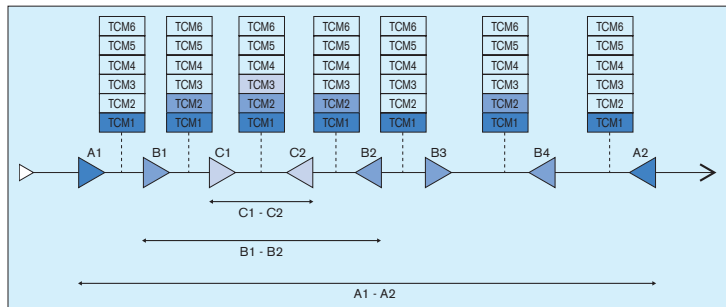

Figure 4.7a – TCM Topologies: Nested

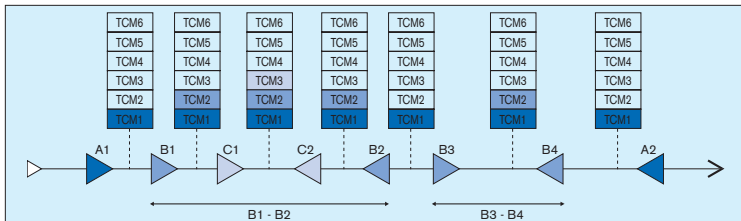

Figure 4.7b – TCM Topologies: Cascaded

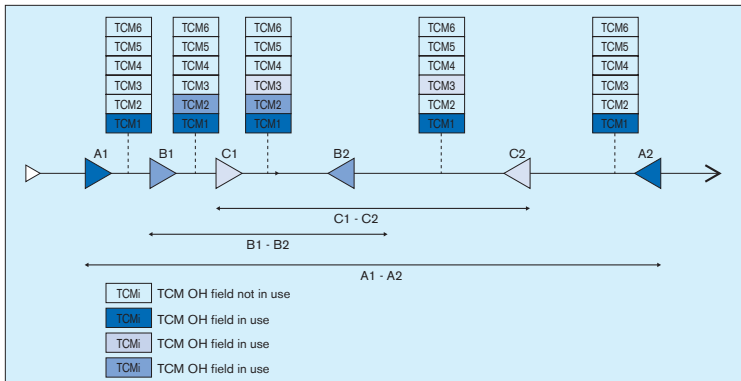

Figure 4.7c – TCM Topologies: Overlapping

4.2.3. Optical Channel Payload Unit (OPU) Overhead

The ITU-T G.709 standard currently defines mappings for constant-bit-rate signals, both bit-synchronous and asynchronous. This includes SONET/SDH, ATM, generic framing procedures (GFP) and pseudo-random bit sequence (PRBS) patterns. As part of the G.709 encapsulation process, the OPU overhead is added to support the adaptation of the various client signals.

The OPU overhead is located in rows 1 to 4 of columns 15 and 16, and it is terminated where the OPU is assembled and disassembled. The OPU overhead consists of the following fields:

- › **Payload structure identifier (PSI)** is a one-byte field allocated in the OPU overhead to transport a 256-byte payload structure identifier (PSI) signal. The PSI byte is located in row 4, column 15 of the OPU overhead.
- › **Payload type (PT)** is a one-byte field defined in the PSI[0] byte and contains the PT identifier that reports the type of payload being carried in the OPU payload to the receiving equipment. Table 4.3 includes all possible payload type values currently defined by the ITU-T G.709 standard.

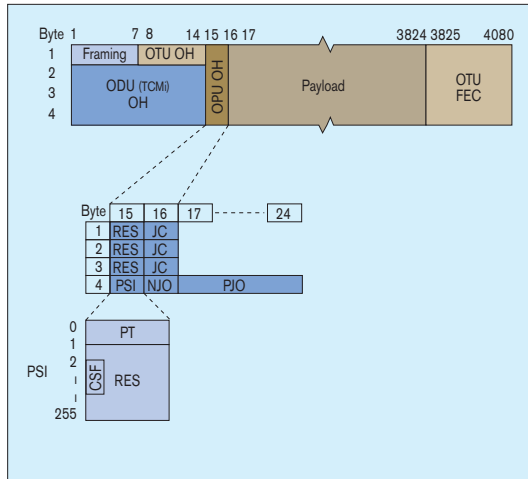

Figure 4.8 – OPU Overhead and PSI Field Structure

MSB 1 2 3 4	LSB 5 6 7 8	Hex Code (Note 1)	Interpretation
0 0 0 0	0 0 0 1	01	Experimental mapping
0 0 0 0	0 0 1 0	02	Asynchronous CBR mapping
0 0 0 0	0 0 1 1	03	Bit-synchronous CBR mapping
0 0 0 0	0 1 0 0	04	ATM mapping
0 0 0 0	0 1 0 1	05	GFP mapping
0 0 0 0	0 1 1 0	06	Virtual Concatenated signal
0 0 0 0	0 1 1 1	07	PCS codeword transparent Ethernet mapping - 100GBASE-X into OPU0 - 40GBASE-R into OPU3 - 100GBASE-R into OPU4
0 0 0 0	1 0 0 0	08	FC-1200 into OPU2e mapping
0 0 0 0	1 0 0 1	09	GFP mapping into Extended OPU2 payload
0 0 0 0	1 0 1 0	0A	STM-1 mapping into OPU0
0 0 0 0	1 0 1 1	0B	STM-4 mapping into OPU0
0 0 0 0	1 1 0 0	0C	FC-100 mapping into OPU0
0 0 0 0	1 1 0 1	0D	FC-200 mapping into OPU1
0 0 0 0	1 1 1 0	0E	FC-400 mapping into OPUflex
0 0 0 0	1 1 1 1	0F	FC-800 mapping into OPUflex
0 0 0 1	0 0 0 0	10	Bit stream with octet timing mapping
0 0 0 1	0 0 0 1	11	Bit stream without octet timing mapping

Table 4.3 – Payload Type (PT) Defined Values

MSB 1 2 3 4	LSB 5 6 7 8	Hex Code (Note 1)	Interpretation
0001	0010	12	IB SDR mapping into OPUflex
0001	0011	13	IB DDR mapping into OPUflex
0001	0100	14	IB QDR mapping into OPUflex
0001	0101	15	SDI mapping into OPU0
0001	0110	16	(1.485/1.001) Gbit/s SDI mapping into OPU1
0001	0111	17	1.485 Gbit/s SDI mapping into OPU1
0001	1000	18	(2.970/1.001) Gbit/s SDI mapping into OPUflex
0001	1001	19	2.970 Gbit/s SDI mapping into OPUflex
0001	1010	1A	SBCON/ESCON mapping into OPU0
0001	1011	1B	DVD_ASI mapping into OPU0
0010	0000	20	ODU multiplex structure supporting ODTUjk only
0010	0001	21	ODU multiplex structure supporting ODTUk.ts or ODTUk.ts and ODTUjk
0101	0101	55	Not available
0110	0110	66	Not available
1000	xxxx	80-8F	Reserved codes for proprietary use
1111	1101	FD	NULL test signal mapping
1111	1110	FE	PRBS test signal mapping
1111	1111	FF	Not available

Table 4.3 – Payload Type (PT) Defined Values

- > **Multiplex structure identifier (MSI)** field is used to encode the ODU multiplex structure in the OPU, and is located in the mapping-specific area of the PSI signal. The MSI indicates the content of each tributary slot (TS) of an OPU.
- > **Justification control (JC)** overhead consists of justification control (JC), negative justification opportunity (NJO) and positive justification opportunity (PJO) signals used in the ODU multiplexing process. The justification overhead bytes are used to make the justification decision in the mapping/demapping process of the client signal to protect against an error in one of the three JC signals.

Field	Definition
Payload structure identifier (PSI)	Defined to transport a 256-byte message aligned with MFAS.
Payload type (PT)	Contains the payload type (PT) identifier that reports the type of payload being carried in the OPU payload to the receiving equipment field, and it is currently undefined in the standard.
Multiplex structure identifier (MSI)	Located in the mapping-specific area of the PSI signal, it is used to encode the ODU multiplex structure in the OPU.
Justification control (JC)	Justification control (JC), negative justification opportunity (NJO) and positive justification opportunity (PJO) signals are used in the ODU multiplexing process to make the justification decision in the mapping/demapping process of the client signal.

Table 4.4 – Summary of OPU Overhead Bytes

4.3. OTU Forward Error Correction (FEC)

Forward error correction (FEC) is a major feature of OTN. It uses a Reed-Solomon RS (255,239) algorithm code to produce redundant information that gets concatenated with the transmitted signal and used at the receive interface to help identify and correct transmission errors. The FEC algorithm has been proven to be effective in systems limited by optical signal-to-noise ratio (OSNR) and dispersion. However, FEC is less effective against polarization mode distortion.

Figure 4.9 - BER vs. E_b/N_0 compares a transport system performance with and without FEC (G.709). Figure 4.9 shows that the transport system with FEC capabilities is able to transmit a signal at a certain bit error rate (BER) with less power (approximately 6 dB) than one without FEC.

In the transmission process according to the RS (255, 239) FEC algorithm, the OTU frame data is separated into four rows and each row split into 16 subrows, as shown in Figure 4.10.

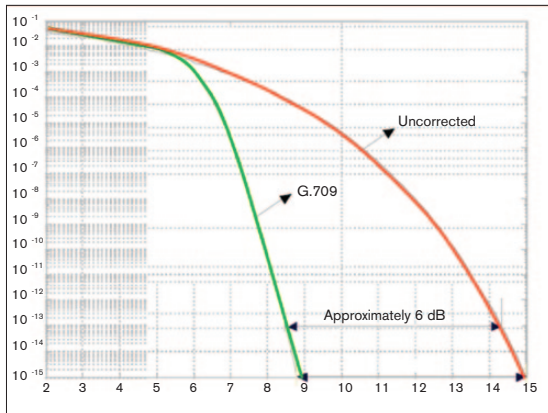

Figure 4.9 - BER vs. E_b/N_0

Figure 4.11 – Forward Error Correction (FEC) Mechanism illustrates the process in which the FEC protocol is interleaving one overhead byte and 238 data bytes to compute 16 parity bytes to form 255-byte blocks; i.e., the RS (255,239) algorithm. The key advantages of interleaving the information are to reduce the encoding rate of each stream relative to the line transmission rate and reduce the sensitivity to bursts of error. The interleaving, combined with the inherent correction strength of the RS (255,239) algorithm, enables the correction of transmission bursts of up to 128 consecutive errored bytes.

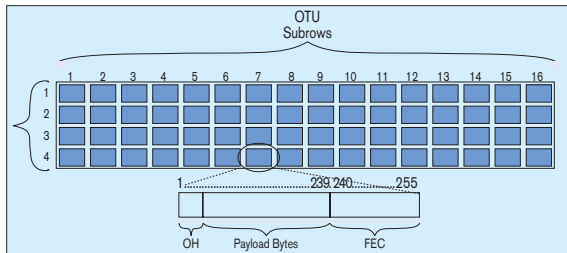

Figure 4.10 – OTU Frame Rows

The coding gain provided by the FEC is used to increase the maximum span length and/or the number of spans, resulting in an extended reach through gain in power level. It also helps increase the number of DWDM channels in a DWDM system and allows the usage of existing 2.5 Gbit/s links to transport 10 Gbit/s traffic. This is in addition to increasing the number of transparent optical network elements that can be crossed by an optical path before amplification is needed. Finally, OTN technology enables today's point-to-point links to evolve into transparent and more efficient meshed optical networks.

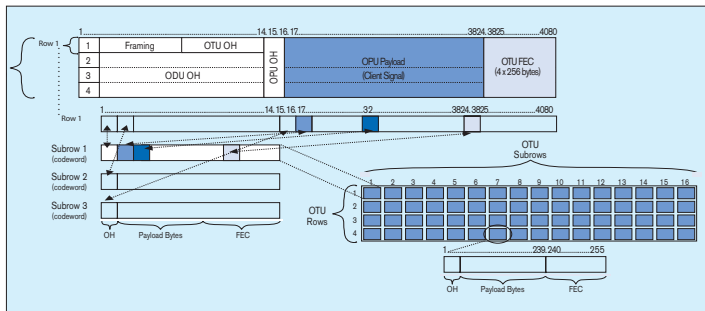

Figure 4.11 – Forward Error Correction (FEC) Mechanism

5

ODU Multiplexing



5. OTN Multiplexing

5.1. ODUk Multiplexing

OTN (G.709) has also defined the multiplexing functions that allow four ODU1s to be multiplexed to an ODU2 and up to sixteen ODU1s, or four ODU2s, to be multiplexed to an ODU3. It is also possible to mix ODU1s and ODU2s in an ODU3. The ODU multiplexing function is essential for optimizing the network resources, including bandwidth usage. Typically, client signals consisting of 2.5 Gbit/s bit streams are transported over a single DWDM wavelength. This might be an efficient service-delivery method if distances are short. However, if such services need to be transported over long distances, it is quite expensive to use a dedicated wavelength.

The G.709 recommendation defines the optical payload unit (OPU), which provides the overhead needed to support the ODU multiplexing function. To multiplex four ODU1s into ODU2, the OPU2 is divided into a number of tributary slots (TS) interleaved within the OPU2, as shown in *Figure 5.1 – ODU1 Multiplexing to ODU2n*. Each OPU2 tributary slot occupies 25% of the OPU2 payload area. In the multiplexing process, the bytes of an ODU1 input are mapped into one of the four OPU2 tributary slots. The multiplex structure identifier (MSI) is used to define the type of multiplexing that is implemented at the transmitter. The MSI is made of PSI Bytes 2 to 17, but when multiplexing ODU1 in ODU2, only Bytes 2 to 5 have a meaning; Bytes 6 to 17 are set to 0, as they are intended for multiplexing applications with ODU3.

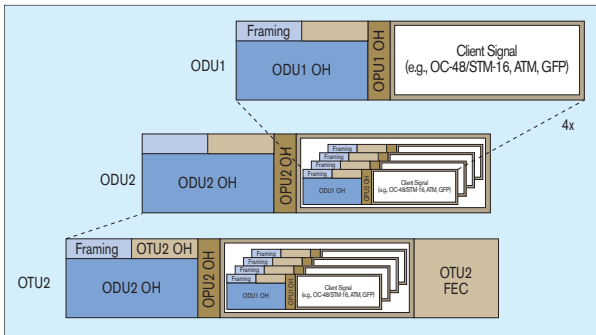

Figure 5.1 – ODU1 Multiplexing to ODU2n

The information carried by the MSI is as follows:

- > ODU type carried by the OPU tributary slots (for example, ODU1 in an OPU2 tributary slot)
- > Tributary port to tributary slot assignment (for example, tributary port 1 mapped to OPU2 tributary slot 1)

In the case of ODU1 in ODU2, the tributary-port-to-tributary-slot assignment is fixed, which means that tributary port 1 is assigned to tributary slot 1 and so on. Finally, an ODU2 overhead is added, after which the ODU2 is mapped into the OTU2 to complete the signal for transport.

The ODU multiplexing functionality of four OC-48/STM-16 signals in one OTU2 is both bit and timing-transparent. This ensures that the integrity of the whole client signal is maintained and the input timing of a synchronous signal is transferred to the far end. ODU multiplexing is also delay-transparent. When four OC-48/STM-16 signals are mapped into ODU1s and then multiplexed into an ODU2, their timing relationship is preserved until they are demapped back to ODU1s at their destinations.

5.2. ODU0

In order to optimize the transport of gigabit Ethernet, a new container was introduced by the G.709 standard; this container, which has an optical channel payload unit (OPU) payload size of 1.238 Gbit/s, provides perfect mapping for gigabit Ethernet traffic. While some multiplexing justification control mechanisms, like generic mapping procedure (GMP), will be used, generic framing procedure (GFP-T) is also used to transcode the Ethernet signal into the payload of the ODU0.

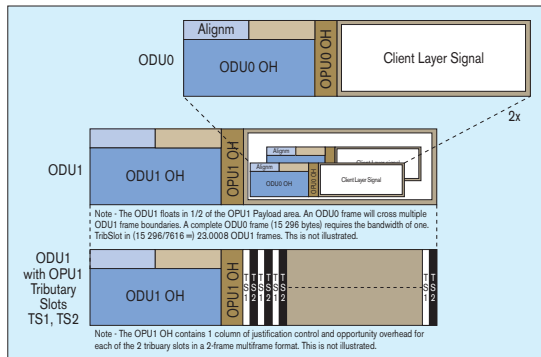

Figure 5.2 – ODU0 Multiplexing to ODUk

In order to inform the receive end on the number of payload bytes that are transported by the OPUk payload for each frame, GMP uses the OPU overhead (OH) justification control bytes. The server frame (or multiframe) is divided into a certain number of GMP 'words'— where each word may contain data:

- > Words containing data are distributed evenly across server frame using sigma/delta distribution algorithm
- > Correct operation depends on the capacity of the mapper/de-mapper to distinguish the number of data 'words' filled into each frame

The number of payload bytes transported is signaled over the justification-control JC1, JC2, JC3 bytes, using the Cm 'word'; the change of number of bytes is signaled with 2 bits designated as increment indicator (II) and decrement indicator (DI). GMP also provides a mechanism to accommodate client signals with tighter jitter requirements (i.e., SONET/SDH client signals). It uses the justification-control JC4, JC5 and JC6 bytes to carry a 10-bit 'word' (designated as: ΣCnD).

The ODU0 container was introduced to deliver greater efficiency in the network. The following figure illustrates how using an ODU0 container for Ethernet mapping results in gained efficiency. Multiple timeslots are allocated for mapping; in the case of an OTU1 (2.5 Gbit/s), there are two time slots allocated—each running at 1.25 Gbit/s—for a total bandwidth around 2.5 Gbit/s. Also, minimal bandwidth loss is observed. Following the same analogy, up to 80 time slots can be allocated in an OTU4 pipe.

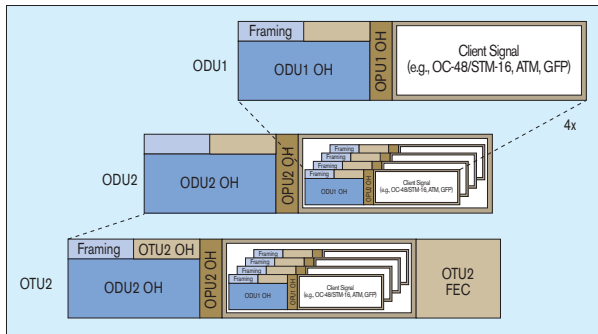

Figure 5.3 – ODU1 Multiplexing to ODU2n

A multistage multiplexing will now be used to bring the lower OTN rate to a higher rate, where an ODU0 could be inserted directly to an ODU4 100G rate.

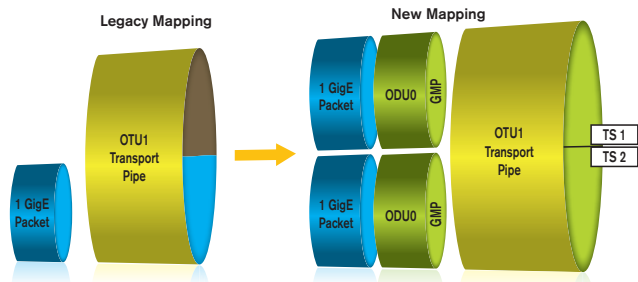

Figure 5.4 - GE Mapping Using the ODU0 Containers multiplexed into ODU1

	2.5G Tributary Slots		1.25G Tributary Slots			
	OPU2	OPU3	OPU1	OPU2	OPU3	OPU4
ODU0	-	-	AMP (PT = 20)	GMP (PT = 21)	GMP (PT = 21)	GMP (PT = 21)
ODU1	AMP (PT = 20)	AMP (PT = 20)	-	AMP (PT = 21)	AMP (PT = 21)	GMP (PT = 21)
ODU2	-	AMP (PT = 20)	-	-	AMP (PT = 21)	GMP (PT = 21)
ODU2e	-	-	-	-	GMP (PT = 21)	GMP (PT = 21)
ODU3	-	-	-	-	-	GMP (PT = 21)
ODUflex	-	-	-	GMP (PT = 21)	GMP (PT = 21)	GMP (PT = 21)

Table 5.1 - Tributary OTN Mapping

5.3. ODUFLEX

Depending on the client signal data rates that need to be transported, having a flexible container can be useful; and ODUflex offers this flexibility. Similar to the VCAT technology used in SONET/SDH, ODUflex provides an efficient and easy solution for mapping packet services and constant bit rate (CBR) signal like fiber channel. It uses 1.25G tributary time slots (ODTUGk) to create a variable container, where a client signal is mapped and then transported over an ODUk signal, for the non-CBR signals ODUflex use generic framing procedure (GFP-F) to map the signal. One of the key advantages of ODUflex is that the unused timeslot can be reused, and the bandwidth is adjustable.

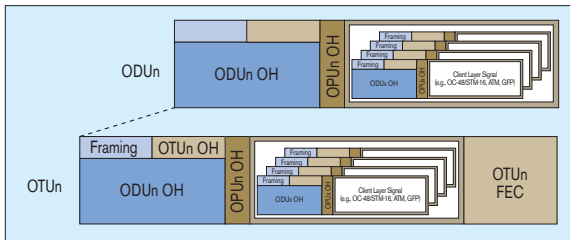

Figure 5.5 – ODUx Multiplexing to OTUn (where $x=0$ to $n-1$)

6

Overclocked Optical Transport Network



6. Overclocked Optical Transport Network

There is an increasing demand for deploying 10 Gbit/s Ethernet LAN/WAN and Fibre Channel services and terminating them across the optical transport layer. Core IP routers are a prime example of this application where multiple 10 Gbit/s interfaces can be terminated in a particular location and transported long distances across the DWDM core optical network. In addition, the integrated packet optical transport networks (P-OTN), built upon the ITU-T's optical transport network (OTN) standards, are efficiently provisioning, transporting and managing legacy TDM services and data-packet services over the same infrastructure.

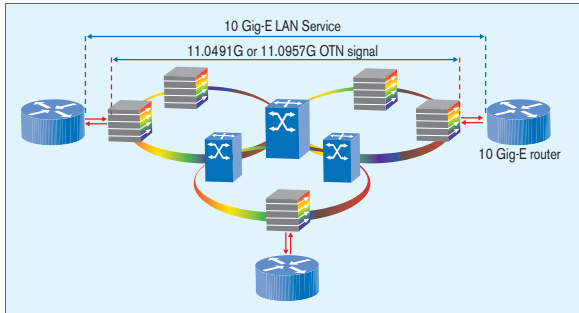

Figure 6.1 – End-to-End IP Connectivity over OTN Networks

Overclocked OTN is a technology that enables the transportation of 10 GbE LAN signals transparently over OTN networks as per ITU-T series G supplement 43 (see Figure 6.1). Overclocked OTN compensates for the rate mismatch between 10 GbE LAN and the OPU2 payload by raising the overall OTU2 data rate from the standard 10.709 Gbit/s to fit the 10 GbE LAN client signal. Obviously with this modification of the standard OTN line rate, interoperability issues will arise and the option for aggregating OTU2 signals into OTU3 is lost; however, ODU3e allows for multiplexing. On the positive side, overclocked OTN offers real bit transparency of 10 GbE LAN signals—a necessity for the mass deployment of 10 G services.

Overclocked OTN supports OTU1e, OTU2e, OTU3e1 and OTU3e2 optical line rates for mapping 10-GigE LAN signals. Furthermore, OTU1f and OTU2f line rates are used for mapping Fibre Channel signals.

G.709 Interface	OTN Line Rate	Corresponding Client Rate
OTU-1e	11.0491 Gbit/s (without stuffing bits)	10 Gig-E LAN (direct mapping over OTN)
OTU-2e	11.0957 Gbit/s (with stuffing bits)	10 Gig-E LAN (direct mapping over OTN)
OTU-1f	11.27 Gbit/s	10G Fibre Channel
OTU-2f	11.3 Gbit/s	10G Fibre Channel
OTU-3e1	44.57 Gbit/s	4 x ODU2e (uses 2.5G TS; total of 16)
OTU-3e2	44.58 Gbit/s	4 x ODU2e (uses 1.25G (ODU0) TS; total of 32)

Table 6.1 – Overclocked OTN rates

The transparent transportation of 10 GigE LAN signals means that the full 10 Gigabit Ethernet data rate (10.3125 Gbit/s) is transported over OTN, including PCS 64B/66B coded information, inter-frame filler (IPG), MAC FCS, preamble, start of frame delimiter (SFD) and ordered sets (remote fault indication). The OTN clocking in this scenario is derived from the Ethernet customer signal (± 100 ppm) rather than that of a standard OTU2 signal (± 20 ppm). Therefore, standard methods for control of jitter and wander—according to G.8251—do not apply in this case, thereby limiting this application to point-to-point data paths.

6.1. OTU2e—10GBASE-R Signal Mapping into OPU2e

The OTU2e (not to be confused with the OTU2, 10.709 Gbit/s signal standard) is a mapping mechanism that uses the mapping scheme of CBR 10 G signals into OPU2, defined in G.709 subclause 17.1.2. The 10GBase-R client signal with fixed stuff bytes is accommodated into an OPU-like signal, then further into an ODU-like signal, and then further into an OTU-like signal. These signals are denoted as OPU2e, ODU2e and OTU2e, respectively.

In the case where the original 10GBase-R input client signal has a different clock rate than the transport layer, a positive or negative bit stuffing would be required for adjustment. Typically, when the input client signal has a rate lower than the transport layer, positive stuffing occurs and when the input client signal has a higher rate, negative stuffing occurs. The location of the stuffing bits is communicated to the receiving end of the data link, where these extra bits are removed to return the bit streams to their original bit rates or form. In this case, the OTU2e signal must be clocked at nominal bit rate of 11.0957 Gbit/s. A unique payload type (PT)—“0x80” reserved code for proprietary—is specified in the payload structure identifier (PSI).

6.2. OTU1e—10GBASE-R Signal Mapping into OPU1e

The OTU1e (not to be confused with OTU1 which is a 2.7 Gbit/s signal) is a mechanism that maps CBR2G5 signals into OPU2 as previously described. However, the fixed stuff bytes of the CBR 10 G mapping are not left free in this mechanism, making the overall data rate somewhat less (11.0491 Gbit/s rather than 11.0957 Gbit/s). Again, the clock tolerance of the underlying Ethernet signal is ± 100 ppm rather than the ± 20 ppm of a standard OTU2 signal. Therefore, standard methods for control of jitter and wander according to G.8251 do not apply again in this case. A unique PT shall be specified in the PSI, e.g., code "0x80" (reserved code for proprietary use).

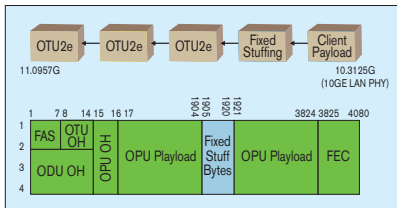

Figure 6.2 – Overclocked OTN with Fixed Stuffing

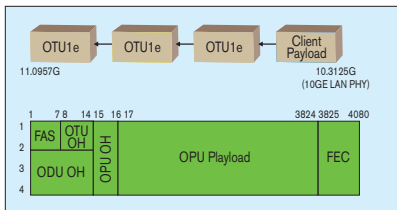

Figure 6.3 – Overclocked OTN without Stuffing

6.3. GFP-F Mapping of 10GBASE-R into OPU2

Generic framing procedure (GFP) is another mechanism for transporting 10 GbE LAN or WAN client signals over OTN. GFP-F encapsulates 10 GbE frames into GFP-F frames first and then into OTU2, according to the G.709 subclause 7.3; GFP-F maps the Ethernet MAC traffic, eliminating the 64B/66B PCS sub-layer. In addition, mapping the GFP-F frames into OPU2 uses the entire OPU2 payload area, meaning that the fixed stuff bytes of the CBR 10 G mapping are not present. Finally, the key benefit of using GFP-F over OTN is to support various data-packet services on the same network.

6.4. ODU2e Signal Mapping into ODU3e

The necessity for network engineers to multiplex 10 Gigabit Ethernet signals directly mapped over OTN led to introduction of the overclocked OTU3e. The OTU3e is a mechanism that allows 10Gig-E LAN signals to be carried directly over 40G OTN networks. Multiplexing ODU2e in OTU3e provides granularity of the 40G circuits, optimizing the payload and simplifying network provisioning and maintenance. The frame structure of the OTU3e2, ODU3e2 and OPU3e2 are the same frame structures as the frame structures of the OTU_k, ODU_k and OPU_k specified in ITU-T G.709. The OPU3e2 carries one or more ODU_j ($j=2e$) signals.



Testing Optical Transport Network Elements



7. Testing Optical Transport Network Elements

Of course, as with every type of network, testing always ensures optimum performance. Among the tests that should be carried out in order for OTN equipment to comply with ITU-T G.709 and ITU-T G.798 are the following:

- > Interface specifications test
- > Response test
- > Conformance and interoperability test
- > Mapping/demapping of client signals test
- > Appropriate FEC behavior test
- > ODU1 to ODU2 multiplexing

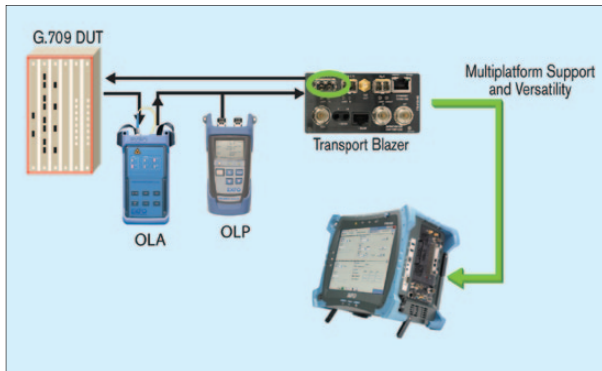

Figure 7.1 – Interface Specifications Test Configuration

7.1. Interface Specifications Test

The interface specifications test is essential to ensure the proper interoperability of equipment from single as well as multiple vendors. The main objective of this test is to verify the input parameters of all interfaces of the G.709 network element under test, including the appropriate OTUk rate, and ensure that synchronization recovery can be properly achieved.

In the interface specification test configuration shown in *Figure 7.1 – Interface Specifications Test Configuration*, the synchronization to the incoming signal must first be checked. For example, clock deviation has to be checked for OTU1 and OTU2 interfaces to ensure it's within the defined ± 20 ppm value.

Additional tests like optical power sensitivity can also be achieved using an optical attenuator to reduce the optical power until the threshold of the input receiver is reached and an optical power meter can be used to measure the minimum supported optical input power.

7.2. Response Test

The network element response test involves sending a stimulus (error or alarm) signal into the device under test (DUT) and monitoring its appropriate output and proper consequence. In OTN, a single stimulus may result in several simultaneous responses. The example shown in *Figure 7.2 - DUT Response Test Configuration* illustrates the test setup and expected responses to a detected loss of signal (LOS) at the receiver.

The response test must be repeated for all possible input stimuli that the DUT is expected to respond to. A list of possible stimuli and their corresponding responses (alarm/error) by the network element under test in upstream and downstream directions are shown in Table 7.1.

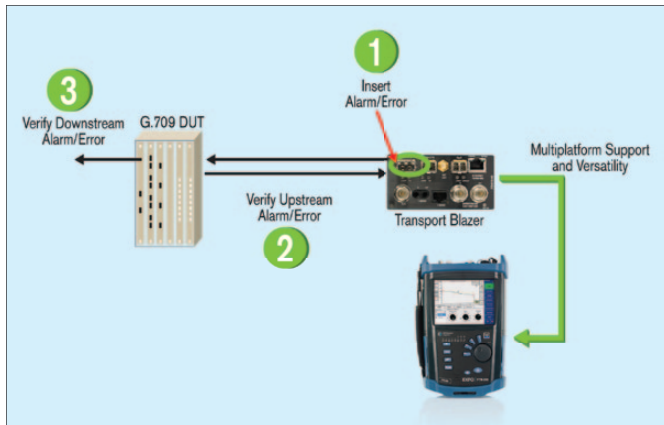

Figure 7.2 – DUT Response Test Configuration

7.3. Conformance and Interoperability Test

The ITU conformance and interoperability test determines the DUT's ability to detect various events under the correct stimulation and standard-specified period of time. Standards normally define entry and exit criteria for alarm events, usually specified by a number of frames or sometimes in a time period. In a similar configuration to the DUT response test shown in *Figure 7.2*, it is recommended to simulate a stimulus condition (alarm/error) over variable test periods. This allows an alarm condition to be simulated for a variable number of frames and to confirm that the entry and exit criteria are met precisely.

7.4. Client Signal Mapping Test

The optical transport hierarchy standard has been designed to transport a range of synchronous and asynchronous payloads. Using OTN decoupled mode, as shown in *Figure 7.3 – Client Signal Mapping Test Configuration*, allows the user to generate a SONET/SDH client signal in the transmit direction and verify the received OTN signal with the mapped SONET/SDH client signal. This configuration enables the test equipment to determine if the DUT successfully recovers the OPU payload under the mapping specifications. When mapping SDH/SONET signal into the OPU, rate differences between the client signal and the OPU clock are accommodated through the use of justification (stuffing) bytes.

Stimulus	Upstream Alarm/Error	Downstream Alarm/Error
LOS-P, LOF, AIS-P, LOM	OTU BDI	OTU-AIS
OTU BIP-8	OTU BEI	–
OTU TIM	OTU BDI	OTU-AIS
OTU IAE	OTU BIAE	–
ODU AIS	ODU BDI	ODU AIS
ODU BIP-8	ODU BEI	–
ODU TIM	ODU BDI	–
ODU OCI	ODU BDI	ODU AIS
ODU PLM	–	ODU AIS

Table 7.1 – Stimulus and DUT Response

The demapping process of a client signal can also be verified in the opposite direction. Using the OTN decoupled mode again, the test equipment can be used to generate an OTN signal with a mapped SONET/SDH client signal on the transmit side and verify the demapped SONET/SDH client signal at the transponder under test.

7.5. Appropriate FEC Behavior Test

As forward error correction (FEC) is a key element of OTN and is used for improving the quality of service, it needs to be validated as part of the G.709 testing. In order to determine the appropriate FEC behavior of the DUT, the test equipment would be used to generate correctable or uncorrectable errors, which would be transmitted through the OTN network element. At the receiving end, the received OTN signal is checked to determine whether or not the errors were corrected or at least detected by the DUT.

This test is performed, as shown in *Figure 7.4 – Appropriate FEC Behavior Test Configuration*, by inserting varying numbers of errors distributed over the FEC portion of the OTN frame and checking the error-correction capability of the DUT. This facilitates the discovery of unexpected behavior without affecting the traffic. An advanced FEC behavior test can be performed by distributing correctable errors at random over the entire OTU frame, which should be recovered by the DUT. If not, then the payload will be affected in this case.

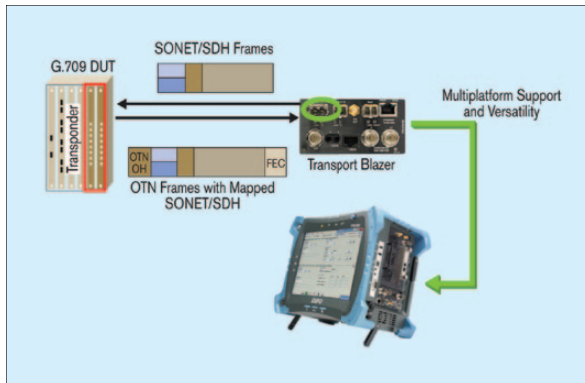

Figure 7.3 – Client Signal Mapping Test Configuration

7.6. ODU1 to ODU2 Multiplexing

ODU1 to ODU2 multiplex functionality testing is also a key parameter that needs to be validated as part of G.709. In order to determine the appropriate multiplexing capability of the network element under test, the test equipment is used in OTN decoupled mode to generate either an OC-48/STM-16 signal or an OTU1 signal on the transmit side. The transmitted signal then gets multiplexed within an ODU2 signal on the G.709 network element with the proper overhead and FEC bandwidth to compose the final OTU2 signal. Finally, the received OTU2 signal is checked at the test equipment to verify the ODU1 to ODU2 multiplexing with the proper with frequency justification and synchronization as shown in *Figure 7.5 – ODU1 to ODU2 Multiplexing Test Configuration*.

7.7. ODU0 to OTU2 Multiplexing

Mapping GigE service into ODU0 is key for qualifying the container as part of a multiplatform network. When performing this test, it is extremely important that the Expected Payload Type (PT) configured at the destination match the Injected Payload Type at the source to obtain full access to Gig-E statistics.

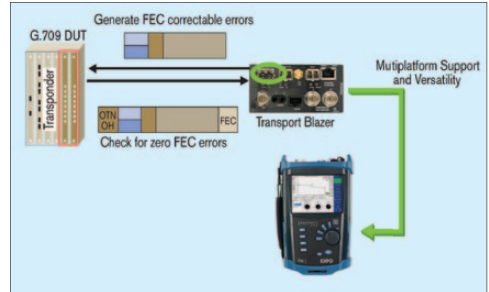

Figure 7.4 – Appropriate FEC Behavior Test Configuration

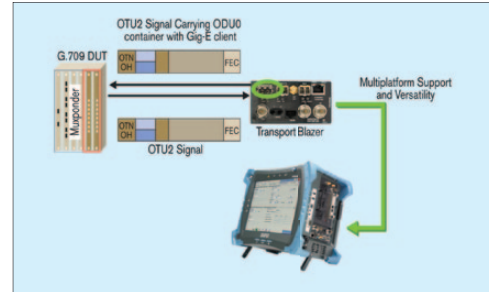

Figure 7.5 – ODU1 to ODU2 Multiplexing Test Configuration

7.8. OTN as a Service

In today's transport networks, OTN is being used from the core to the edge. At the core, OTN is used to transport high speed rates of 10, 40 and 100 Gbit/s. In edge networks, where it is just starting to gain momentum, OTN offers a multitude of benefits to both operators and customers alike. Among the many advantages, it offers complete end-to-end performance monitoring throughout the entire network rather than just at the edge, thereby providing robust alarm and error monitoring. Here are a few more advantages that service providers should be aware of:

- > Flexibility of services (e.g., you can have 10 Gigabit Ethernet or OC 192/STM-64 over an OTU2 service, or even higher Gigabit Ethernet in an OTU0 without "burning" bandwidth).
- > OTN can be used to transport legacy services, but also allows for convergence to MEF Carrier Ethernet 2.0. Accordingly, it can be qualified as a "pay-as-you-grow" architecture.
- > OTN has built-in OAM capabilities that far exceed some legacy technologies, meaning that it improves quality of service (QoS).

As a service, OTN offers improved flexibility for optimization of the transport container through the addition of lower-order ODU0 and ODUFlex containers. (For more information about ODU0 and ODUFlex, please see their respective sections in this pocket guide.) And, with the help of a new generic mapping procedure (GMP), the flex concept optimizes client mapping of any bit rate into any larger bit-rate container without the need for unique mappings for each client/container pair. GMP is used for mapping transcoded 1 Gigabit Ethernet or any constant bit rate traffic into an OPU0 or ODUFlex, all the way up to a higher-order OPU4. As previously described, the flexibility and efficiency of OTN circuits is very attractive to service providers who are planning to expand into new revenue streams and offer more services. Figure 7.8.1 below details the transparency and flexibility offered by OTN, which is now optimized to support any client signal.

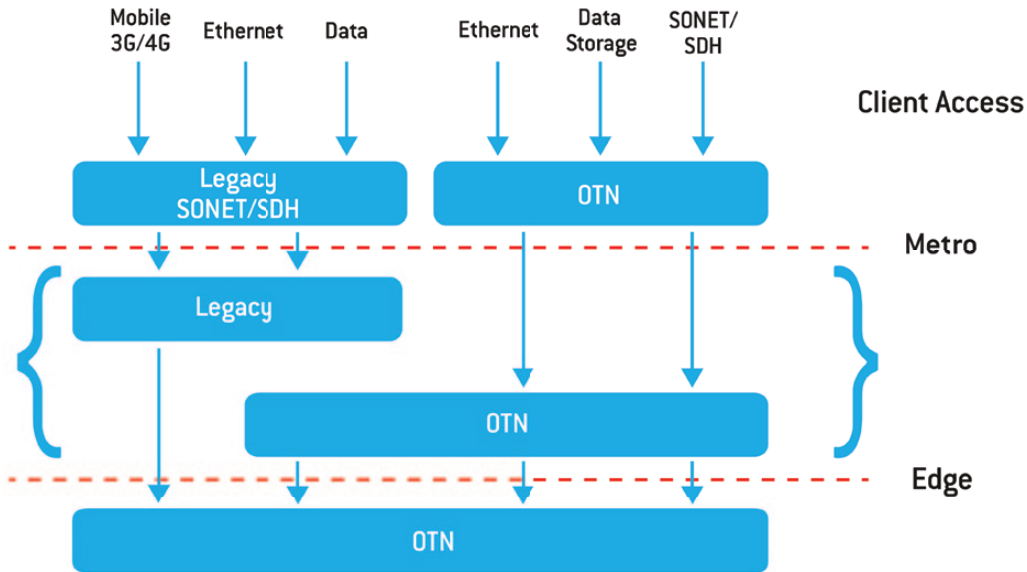

7.8.1 Today's OTN structure

The same test that used to be located in the metro and edge will now need to be performed on the access side, introducing new challenges for technicians who are used to working with Ethernet, IP, Fiber Channel (FC), SONET/SDH and other technologies. Some of these challenges are as follows:

- > The need to develop new service turn-up procedures
- > Training and educating field technicians in OTN technology
- > Test equipment availability
- > Testing and troubleshooting procedures

As shown in Figure 7.8.2, the new challenges extend from one end of the network to the other, but can be reduced with the appropriate test equipment offering a simple user interface and support for a wide range of client signals, including SONET/SDH, FC, ETHERNET and OTN. As an added benefit, an all-in-one test equipment solution will also reduce the technician learning curve, which translates into reduced costs for carriers and service providers.

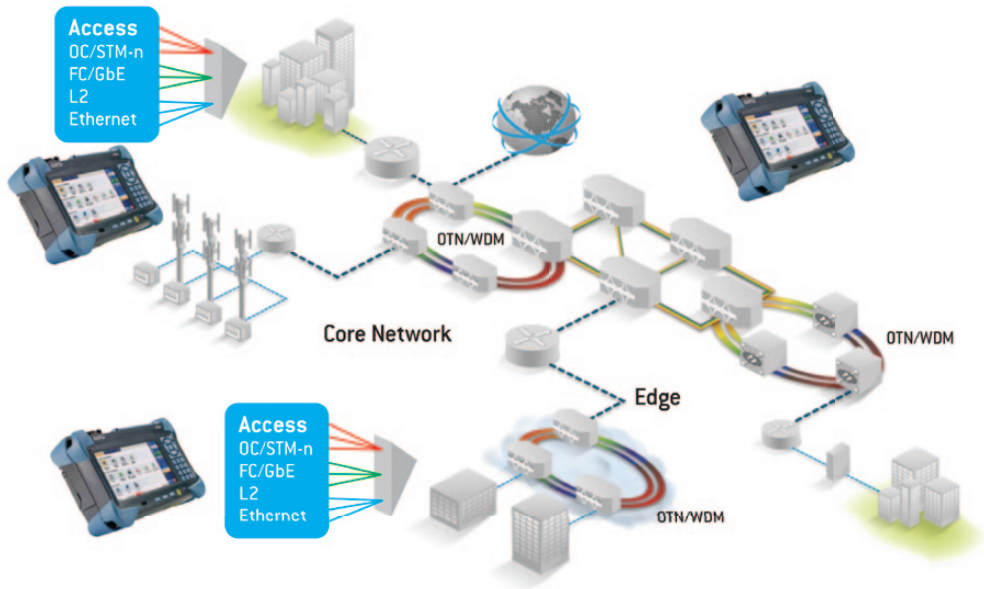

Figure 7.8.2 End-to-end OTN test configuration

8

Conclusion



8. Conclusion

To satisfy the growing demand for bandwidth, control costs and still remain competitive, service providers are deploying the next-generation optical transport networks defined by ITU-T G.709. The G.709 technology includes forward error correction and enhanced network management, delivering a function comparable to the effect of SONET/SDH on a single wavelength with full transparency.

Today, service providers are faced with the challenge of building up their confidence in the new OTN network and its promised improved performance to the end users. This is made possible with the introduction of the G.709 testing capabilities in the test and measurement market. Service providers are now equipped with the full spectrum of G.709 testing equipment for lab standardization, interoperability testing, field deployment and troubleshooting.

9

Acronyms



9. Acronyms

APS	Automatic Protection Switching
AIS	Alarm Indication Signal
BDI	Backward Defect Indication
BEI	Backward Error Indication
BIP-8	Bit-Interleaved Parity-8
BIAE	Backward Incoming Alignment Error
CSF	Client Signal Fail
DAPI	Destination Access Point Identifier
DUT	Device Under Test
DWDM	Dense Wavelength-Division Multiplexing
DW	Digital Wrapper
EXP	Experimental
FEC	Forward Error Correction
FTFL	Fault Type Fault Location
FAS	Frame Alignment Signal
GFP	Generic Framing Procedure
GCC	General Communication Channel
IdI	Intra-Domain Interface
IrDI	Inter-Domain Interface
IAE	Incoming Alignment Error
LOF	Loss of Frame

LOFLOM	Loss of Frame and Loss of Multi-Frame
LOL	Loss of Lane Alignment
LOOMFI	Loss of OPU Multi-Frame Identifier
LOR	Loss of Recovery
LOS	Loss of Signal
LCK	Locked
MFAS	Multiframe Alignment Signal
MSI	Multiplex Structure Identifier
NE	Network Element
OCh	Optical Channel
OH	Overhead
OLA	Optical Attenuator
OLP	Optical Power Meter
OMFI	OPU Multi-Frame Identifier
OOR	Out of Recovery
OPU	Optical Channel Payload Unit
OTN	Optical Transport Network
OTU	Optical Channel Transport Unit
OMS	Optical Multiplexing Section
OTS	Optical Transmission Section

OSC	Optical Supervisory Channel
ODU	Optical Channel Data Unit
OAM&P	Operations, Administration, Maintenance & Provisioning
OADM	Optical Add/Drop Multiplexer
OOF	Out of Frame
OOM	Out of Multiframe
OCI	Open Connection Indication
OSNR	Optical Signal-to-Noise Ratio
PSI	Payload Structure Identifier
PCC	Protection Communication Channel
PM	Performance Monitoring
PT	Payload Type
PRBS	Pseudo-Random Bit Sequence
PMD	Polarization Mode Distortion
RS	Reed Solomon
RES	Reserved
SAPI	Source Access Point Identifier
SM	Section Monitoring
SONET	Synchronous Optical Network
SDH	Synchronous Digital Hierarchy

STAT	Status
TCM	Tandem Connection Monitoring
TTI	Trail Trace Identifier

NOTES

No part of this guide may be reproduced in any form
or by any means without the prior written permission of EXFO.

Printed and bound in Canada

ISBN 1-55342-008-X

Legal Deposit—National Library of Canada 2007

Legal Deposit—National Library of Quebec 2007



For details on any of our products and services, or to download technical and application notes, visit our website at www.EXFO.com.

EXFO