

Next-Generation SONET/SDH Reference Guide

Your everyday SONET/SDH testing reference tool

Next-Generation Network Assessment



About EXFO

EXFO is a recognized test and measurement expert in the global telecommunications industry through the design and manufacture of advanced and innovative solutions as well as best-in-class customer support. The Telecom Division, which represents the company's main business activity, offers fully integrated and complete test solutions to network service providers, system vendors and component manufacturers in approximately 70 countries. One of EXFO's strongest competitive advantages is its PC/Windows-based modular platforms that host a wide range of tests across optical, physical, data and network layers, while maximizing technology reuse across several market segments. The Photonics and Life Sciences Division mainly leverages core telecom technologies to offer value-added solutions in the life sciences and high-precision assembly sectors. For more information about EXFO, visit www.EXFO.com.

Table of Contents

1. Introduction	3
2. SONET/SDH Basics	5
2.1 Transport Rates.....	5
2.2 Multiplexing Scheme.....	6
2.3 Network Hierarchy.....	9
2.4 Basic Frame.....	12
2.4.1 SONET STS-1 Frame Format.....	12
2.4.2 STM-1 Frame Format.....	18
2.5 Virtual Tributaries/Containers.....	23
2.5.1 SONET Virtual Tributaries.....	24
2.5.2 SDH Virtual Tributaries.....	25
3. Why Next-Generation SONET/SDH?	28
4. Generic Framing Procedure (GFP)	31
4.1 GFP Mapping.....	32
4.2 GFP Frame Structure.....	34
4.3 GFP Summary.....	40
5. Virtual Concatenation (VCAT)	42
5.1 High-Order VCAT.....	45
5.1.1 High-Order VCAT Frame Structure.....	45
5.1.2 High-Order VCAT Multiframe Indicator.....	47
5.1.3 High-Order Path Sequence Indicator.....	48
5.2 Low-Order VCAT.....	49
5.2.1 Low-Order VCAT Frame Structure.....	49
5.2.2 Low-Order VCAT Multiframe and Sequence Indicator.....	51
5.3 VCAT Differential Delay.....	52
5.4 VCAT Summary.....	53
6. Link-Capacity Adjustment Scheme (LCAS)	55
6.1 LCAS Control Packets.....	57
6.2 LCAS Example 1: Capacity Increase.....	58
6.3 LCAS Example 2: Capacity Reduction.....	61
7. Next-Generation SONET/SDH: Testing Implications	66
7.1 GFP Test Scenarios.....	66
7.2 VCAT Test Scenarios.....	69
7.3 LCAS Test Scenarios.....	72
7.4 Continuity and Performance Testing.....	74
7.5 Service Turn-Up Testing.....	74
7.6 Network Troubleshooting.....	78
8. Conclusion	81
9. Next-Generation Alarms Index	83
10. Acronyms Index	87
11. References	90
Acknowledgements	93

The background of the slide is a blurred, abstract image of a globe. It features curved, concentric bands of color, primarily yellow and blue, which suggest the curvature of the Earth. The colors are soft and out of focus, creating a sense of depth and movement.

1

Introduction

1. Introduction to SONET/SDH Technology

SONET/SDH networks have stood the test of time and, until recently, they have been primarily used to transport aggregated voice signals and private-line frame-relay and ATM services. The growth of these high-revenue-generating services over the years has resulted in large-scale deployments of metropolitan and long-haul SONET/SDH networks worldwide.

Today, however, service demand and, consequently, service-provider revenue growth has shifted from these legacy-based services to IP/Ethernet-based services. This shift in demand is largely due to two market factors. First, enterprise customers have expressed an increasing need for reliable Ethernet-based transport services and, second, Ethernet is becoming the Layer 2 transport technology of choice for both enterprise connectivity and access aggregation networks. In addition, with the convergence of voice, video and data (e.g., triple-play access networks), Ethernet connections are now being used for delivery of mission-critical services, thus making 99.999% reliability an absolute service requirement for these enterprise customers.

This growing demand for Ethernet-based transport services has led to a “rebirth” of SONET/SDH. Given the fundamental robustness of the technology and the massive capital investment that has been made over the years, service providers have been eager to find ways of using their existing SONET/SDH infrastructure to fulfill the growing market demand for Ethernet.

Packet-aware SONET/SDH add-drop multiplexers, commonly known as multiservice provisioning platforms (MSPPs), are actively being deployed in service-provider networks worldwide, as they offer an efficient means of transporting packet-based client signals, such as Ethernet and Fibre Channel, over existing SONET/SDH infrastructures. This efficiency is provided through their support of recent ITU and ANSI standards; namely, generic framing procedure (GFP), virtual concatenation (VCAT), and link-capacity adjustment scheme (LCAS).

This pocket guide begins by providing a refresher on SONET/SDH and then presents an in-depth look into these newly introduced next-generation SONET/SDH technologies, outlining their applications and the test scenarios that equipment vendors and service providers must consider when qualifying MSPPs and when activating and maintaining Ethernet-over-SONET/SDH circuits, as well as other network elements.

2

SONET/SDH Basics

2. SONET/SDH Basics

Synchronous Optical NETWORKing – commonly known as SONET – and Synchronous Digital Hierarchy (SDH) have been around for decades. Although well understood within the telecommunications industry, when discussing next-generation SONET/SDH technologies, it is important to provide a quick refresher of the basic workings of SONET/SDH.

SONET and SDH standards were developed for communicating digital information over optical fiber. The SONET specifications define optical-carrier (OC) interfaces and their electrical equivalents to allow for transmission of lower-rate signals at a common synchronous rate. These specifications were developed to replace the lower-rate T-Carrier/PDH systems, as they allow for the transport of large amounts of telephony and data traffic.

Both SONET and SDH are widely used today; SONET mainly in North America, and SDH in the rest of the world.

One of the benefits of the SONET/SDH signal, as with any standard, is that it facilitates the interoperability between multiple vendors within the same network. Another major advantage of SONET/SDH is that the operations, administration, maintenance, and provisioning (OAM&P) capabilities are built directly into the signal overhead to allow for maintenance of the network from one central location.

2.1 Transport Rates

The following table outlines common SONET/SDH data rates supported in the standard.

Table 2.1 – Common SONET/SDH Data Rates

Optical Level	Electrical Level	Line Rate (Mbit/s)	Payload Rate (Mbit/s)	SDH Equivalent
OC-1	STS-1	51.840	48.38	STM-0
OC-3	STS-3	155.520	149.76	STM-1
OC-12	STS-12	622.080	599.04	STM-4
OC-48	STS-48	2,488.320	2,396.16	STM-16
OC-192	STS-192	9,953.280	9,584.64	STM-64
OC-768	STS-768	39,813.120	38,486.016	STM-256

2.2 Multiplexing Scheme

SONET/SDH signals can carry large payloads (above 50 Mbit/s). However, the existing digital hierarchy signals can be accommodated as well, thus protecting network investments. To achieve this capability in SONET, the STS synchronous payload envelope can be subdivided into smaller components or structures, known as virtual tributaries (VTs), for the purpose of transporting and switching payloads smaller than the STS-1 rate. All services below the DS3 rate are transported in the VT structure. The following four multiplexing principles are used in both SONET and SDH:

- Mapping – This process takes place when tributaries are integrated into virtual tributaries (VTs) in SONET, or into virtual containers (VCs) in SDH, by adding justification bits and path overhead (POH) information.
- Aligning – This process takes place when a pointer is included in the STS path or VT path overhead to allow the first byte of the virtual tributary to be located. Similarly, aligning is used in SDH when a pointer is included in a tributary unit (TU) or an administrative unit (AU).
- Multiplexing – This process is used when multiple lower-order path-layer signals are integrated into a higher-order path signal, or when the higher-order path signals are integrated into the line overhead (in SONET) or into the multiplex section (in SDH).
- Stuffing – SONET and SDH both have the ability to handle various input tributary rates from asynchronous signals or PDH. As the tributary signals are multiplexed and aligned, some spare capacity has been designed into the SONET or SDH frame to provide enough space for all these tributary rates.

Figure 2.2 illustrates the SDH multiplexing scheme. Low-rate signals are input into virtual containers (VC) to create a uniform VC payload. Next, VCs are aligned into tributary units (TUs), and then the payload is multiplexed into TU groups (TUGs). The next step is multiplexing the TUGs to higher-rate VCs and then the VCs into administrative units (AUs). The AUs are finally multiplexed into the AU group (AUG), and the payload is multiplexed into the synchronous transport module (STM).

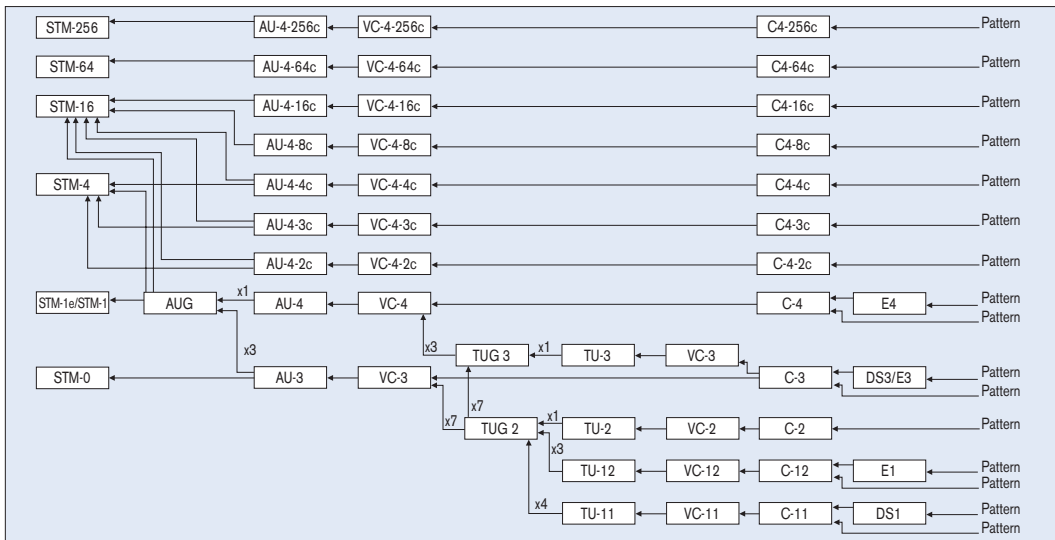

Figure 2.2 SDH Multiplexing Hierarchy

2.3 Network Hierarchy

SONET and SDH are like other layered protocols in the sense that their layers communicate with other similar-type layers. SONET sections and SDH regenerator sections (RS) are defined as links between any two SONET network elements. A SONET line or an SDH multiplex section (MS) represents a link between any two SONET or SDH multiplexers. A path represents the entire portion of the network over which a SONET/SDH signal is being transported. Each layer checks for header information, which may include alarms, pointers, and maintenance information. Below is a detailed description of the four layers contained in the SONET/SDH architecture.

■ Photonic Layer

The photonic layer refers to the optical properties of the transmission path, which involves the sending of serial 0s and 1s from a sender to a receiver across the physical medium. No overhead is associated with this layer. The main function of this layer is to convert STS electrical frames into optical OC bit signals.

■ Section/Regenerator Section Layer

The SONET section or the SDH regenerator section layer refers to the regenerator section of the transmission link. This layer manages the transport of STS/STM frames across the physical path, using the photonic layer. Its functions include error monitoring, framing, signal scrambling, and transport of overhead. Section/regenerator section overhead consists of nine bytes of information that contain the information required for this layer to perform its functions. The overhead is created or used by what is known as section-terminating equipment (STE) in SONET and regenerator section-terminating equipment (RSTE) in SDH.

Line/Multiplex Section Layer

The SONET line layer or the SDH multiplex section layer refers to the maintenance span, which forms a segment between two SONET/SDH devices, excluding the lower-layer regenerators. A single SONET/SDH link from one user site to another may consist of many such spans.

This layer manages the transport of the SONET/SDH payloads, which are embedded in a sequence of STS frames, across the physical medium. Functions of the line/multiplex section layer include multiplexing and synchronization, both required for creating and maintaining SONET/SDH payloads. Overhead bytes provide this layer with the ability to perform its functions, to communicate with the layers that surround it, and to provide certain protection and maintenance features. This overhead is used and created by the SONET line-terminating equipment (LTE) and the SDH multiplex section-terminating equipment (MSTE).

Path Layer

The path layer covers end-to-end or customer-to-customer transmission. One end of the path is always where the bits in the SONET/SDH payload originate, and the other end of the path is always where the bits in the synchronous payload envelope (SPE) terminate. The path overhead (POH) associated with the SONET/SDH path is considered to be part of the SPE. The POH is passed unchanged through the other SONET/SDH layers.

The path layer transports actual network services between SONET/SDH multiplexing equipment. These devices would include the transport of customer DS-1s, DS-3s, ATM cells, and so on. The path layer maps these service components into a format recognized by the line layer and then communicates end to end, using functions made possible by the POH bytes to ensure overall transmission integrity. The POH retains the data (payload) until it reaches the other end of the SONET/SDH link.

The purpose behind this layering is to divide responsibility for transporting the payload through the network. Each network element (NE) is responsible for interpreting and generating its overhead layer and for communicating control and status information to the corresponding layer of the other equipment. As the payload travels through the SONET network, each layer is terminated by one of a general class of NEs, termed section-terminating equipment (STE), line-terminating equipment (LTE), or path-terminating equipment (PTE) in SONET, or equivalent equipment in SDH.

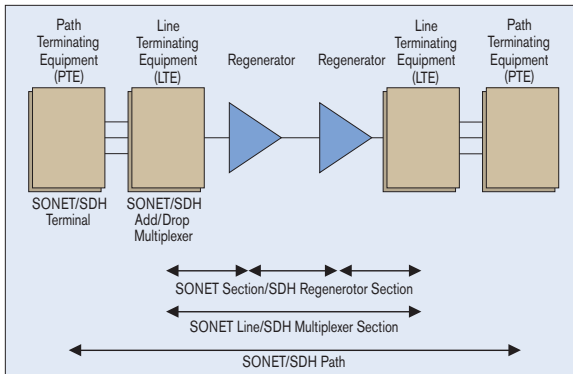

Figure 2.3 SONET/SDH Network Layers

Figure 2.3 illustrates a sample network with the layered functions identified. The POH is generated at the point where the lower-rate signal enters the SONET/SDH network, and it is removed when the payload exits the network. Since the POH is first-on/last-off, alarm and error information contained within this layer represents end-to-end status. The next layer of overhead termination is the LOH/MSOH and is performed by the add/drop multiplexer (ADM). The overhead is where most of the communication and synchronization between NEs occur. Finally, SOH/RSOH is terminated by optical regenerators and contains error information between every node in the network.

Note: Section and line are commonly referred to as the regenerator section and the multiplexer section, respectively, within the context of SDH networks.

2.4 Basic Frame

2.4.1 SONET STS-1 Frame Format

The basic building block of the SONET digital transmission hierarchy is the STS-1 frame. The basic STS-1 frame consists of 810 bytes, transmitted 8000 times per second to form a 51.840 Mbit/s signal rate. Figure 2.4 illustrates the basic SONET frame structure. The STS-1 frame consists of 9 rows of 90 columns. The STS-1 frame is transmitted one row at a time, from top to bottom, and from left to right within each row. Therefore, the byte in Row 1, Column 1 is sent first, and the byte in Row 9, Column 90 is sent last. After the 90th byte is sent at the end of Row 1, the next byte sent is the first byte in Row 2, Column 1.

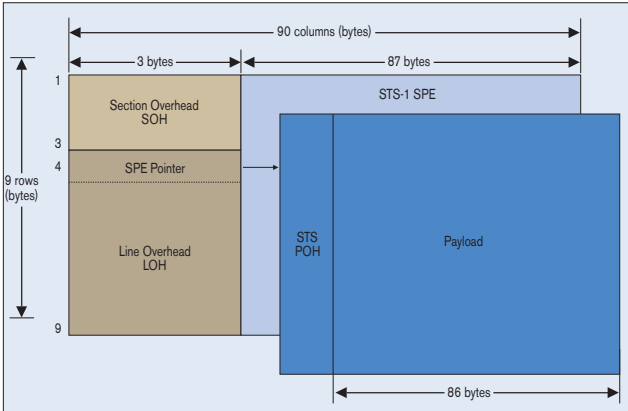

Figure 2.4 STS-1 Frame Structure

An STS frame is composed of two main sections. The first three columns of the STS-1 frame form the transport overhead (TOH) for the entire frame. All of the SONET overhead information (divided into section, line, and path) that is used to manage defined parts of the SONET network and transported data is in the first three columns of the frame. This overhead section, therefore, consists of 27 bytes (9 rows x 3 bytes/row) sent as part of each and every SONET frame. The remaining 87 columns of the STS constitute the SPE capacity, which combines the path overhead and the actual user data.

All SONET frames are sent 8000 times per second and all SONET frames are exactly 9 rows. The only variable is the number of columns, resulting in all of the different speeds at which the SONET operates. In order to build up STS-N frame structures that operate faster, STS-1 frames can be multiplexed to create a SONET-super-rate frame. For example, three STS-1s can be multiplexed into a single STS-3 frame and sent on an OC-3 signal. The three STS-1s are still considered three independent frame streams and each has its own set of payload pointers. All of the user information must fit within an STS-1 frame's synchronous payload envelope (SPE), and the frames are simply multiplexed prior to transmission so that the fiber can be used more efficiently by using higher speeds. Concatenated payloads are an exception and will be discussed further in this guide.

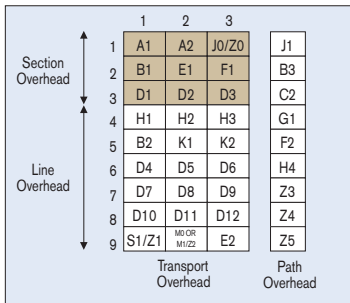

Figure 2.5 SONET Overhead

SONET Overhead

SONET provides substantial overhead information, allowing for simpler multiplexing and comprehensive operations, administration, maintenance, and provisioning (OAM&P) capabilities. The overhead information has several layers (shown in Figure 2.5): path overhead, line overhead, and section overhead. Enough information is contained in the overhead to allow the network to operate and allow OAM&P communications between an intelligent network controller (i.e., a network management system) and the individual nodes. The following sections detail the different SONET overhead information, as defined in GR-253/ANSI T1.105:

- Section Overhead:** The SOH contains overhead information used by all SONET equipment along a network path, including signal regenerator. It is contained in the top three bytes of the first three columns in the basic STS-1 frame structure. This overhead supports functions such as performance monitoring, local orderwire, and data communication channels, carrying information for OAM&P. Table 2.2 lists the SOH's nine constituent bytes and their corresponding functions.

Table 2.2 – Section Overhead

Byte	Description
A1, A2	Framing bytes – These two bytes indicate the beginning of an STS-1 frame.
J0	Section trace (J0)/section growth (Z0) – The byte in each of the N STS-1s in an STS-N that was formally defined as the STS-1 ID (C1) byte has now been refined either as the section-trace byte (in the first STS-1 of the STS-N), or as a section-growth byte (in the second through Nth STS-1s).
B1	Section bit-interleaved parity code (BIP-8) byte – This is a parity code (even parity) used to check for transmission errors over a regenerator section. Its value is calculated over all bits of the previous STS-N frame after scrambling and then placed in the B1 byte of STS-1 before scrambling. Therefore, this byte is defined only for STS-1, Number 1 of an STS-N signal.
E1	Section orderwire byte – This byte is allocated to be used for voice communication between regenerators, hubs, and remote terminal locations.
F1	Section user-channel byte – This byte is set aside for users' purposes. It terminates at all section-terminating equipment within a line.
D1, D2, D3	Section data-communications channel (DCC) bytes – Together, these three bytes form a 192 kbit/s message channel, providing a means of communication between the various parts of section-terminating equipment and thus enabling operations, administration, maintenance, and provisioning (OAM&P).

- **Line Overhead:** The LOH is contained in the bottom six bytes of the first three columns. This overhead is processed by all elements in the SONET network, except for the regenerators. Line overhead supports functions such as: locating the SPE in the frame, multiplexing or concatenating signals, performance monitoring, automatic protection switching, and line maintenance. The line overhead is found in Rows 4 to 9 of Columns 1 through 9. Table 2.3 lists the LOH bytes and their corresponding functions.

Table 2.3 – Line Overhead

Byte	Description
H1, H2	STS payload pointer (H1 and H2) – Two bytes are allocated to a pointer that indicates the offset in bytes between the pointer and the first byte of the STS SPE. The pointer bytes are used in all STS-1s within an STS-N to align the STS-1 transport overhead in the STS-N and to perform frequency justification. These bytes are also used to indicate concatenation and to detect STS path alarm-indication signals (AIS-P).
H3	Pointer action byte (H3) – This byte is allocated for SPE frequency justification purposes. The H3 byte is used in all STS-1s within an STS-N to carry the extra SPE byte in the event of a negative pointer adjustment.
B2	Line bit-interleaved parity code (BIP-8) byte – This parity code byte is used to determine if a transmission error has occurred over a line. It's even parity and is calculated over all bits of the line overhead and STS-1 SPE of the previous STS-1 frame before scrambling. This byte is provided in all STS-1 signals in an STS-N signal.
K1, K2	Automatic protection-switching (APS channel) bytes – These two bytes are used for protection signaling between line-terminating entities for bidirectional automatic protection switching and for detecting alarm-indication signal (AIS-L) and remote defect-indication (RDI) signals.
D4 to D12	Line data-communications channel (DCC) bytes – These nine bytes form a 576 kbit/s message channel from a central location for OAM&P information (alarms, control, maintenance, remote provisioning, monitoring, administration, and other communication needs) sent between line entities. Available for internally generated, externally generated, and manufacturer-specific messages.
S1	Synchronization status (S1) – The S1 byte is located in the first STS-1 of an STS-N, and bits 5 through 8 of that byte are allocated to convey the synchronization status of the network element.
Z1	Growth (Z1) – The Z1 byte is located in the second through Nth STS-1s of an STS-N ($3 \leq N \leq 48$), and is allocated for future growth.
M0	STS-1 REI-L (M0) – The M0 byte is only defined for STS-1 in an OC-1 or STS-1 electrical signal. Bits 5 through 8 are allocated for a line remote-error-indication (REI-L) function.

Table 2.3 – Line Overhead (continued)

Byte	Description
M0	STS-1 REI-L (M0) – The M0 byte is only defined for STS-1 in an OC-1 or STS-1 electrical signal. Bits 5 through 8 are allocated for a line remote-error-indication (REI-L) function.
M1	STS-N REI-L (M1) – The M1 byte is located in the third STS-1 (in order of appearance in the byte-interleaved STS-N electrical or OC-N signal) in an STS-N ($N \leq 3$), and is used for a REI-L function.
Z2	Growth (Z2) – The Z2 byte is located in the first and second STS-1s of an STS-3, and the first, second, and fourth through Nth STS-1s of an STS-N ($12 \leq N \leq 48$). These bytes are allocated for future growth.
E2	Orderwire byte – This orderwire byte provides a 64 kbit/s voice channel between line entities.

- **Path Overhead:** In addition to user data, the SPE contains path overhead (POH) bytes; namely, high-order and low-order path overhead.

- *Low-Order Path Overhead:* In the case of a virtual signal, the VT POH (also known as low-order POH) contains four evenly distributed POH bytes per VT SPE, starting at the first byte of the VT SPE. VT POH provides means for communication between the point of creation of a VT SPE and its point of disassembly. Table 2.4a lists the VT POH bytes and their corresponding functions.

Table 2.4a – Low-Order Path Overhead

Byte	Description
V5	This byte provides the same functions for the VT paths as the B3, C2 and G1 bytes provide for STS paths, including error checking, signal labeling, and path status indication.
J2	This byte is a VT path trace identifier used to transmit repetitive fixed-length messages (typically 16 or 64 bytes in sequence length).
Z6	This byte provides support for low-order tandem-connection monitoring.
Z7	This byte is used to enable APS signaling and extended RDI (ERDI) capability.

- *High-Order Path Overhead*: The POH bytes, also known as STS POH or high-order POH, are processed at the SONET STS-1 terminating equipment because they travel as part of the payload envelope. The SPE contains nine bytes of POH supporting functions such as performance monitoring of the STS SPE, signal label, path status, and path trace. The path overhead is found in Rows 1 to 9 of the first column of the STS-1 SPE. Table 2.4b lists the POH bytes and their corresponding functions.

Table 2.4b – High-Order Path Overhead

Byte	Description
J1	STS path trace byte – This user-programmable byte repetitively transmits a 64-byte, or 16-byte format string allowing the receiving terminal in a path to verify its continued connection to the intended transmitting terminal.
B3	STS path bit-interleaved parity code (Path BIP-8) byte – This is a parity code (even), used to determine if a transmission error has occurred over a path.
C2	STS path signal label byte – This byte is used to indicate the content of the STS SPE, including the status of the mapped payloads.
G1	Path status byte – This byte is used to convey the path-terminating status and performance back to the originating path-terminating equipment. Bits 1 through 4 are allocated for an STS Path REI function (REI-P). Bits 5, 6, and 7 of the G1 byte are allocated for an STS Path RDI (RDI-P) signal. Bit 8 of the G1 byte is currently undefined.
F2	Path user-channel byte – This byte is used for user communication between path elements.
H4	Virtual tributary (VT) multiframe indicator byte – This byte provides a generalized multiframe indicator for payload containers. At present, it is used for tributary unit structured payloads, as well as virtual concatenation functions.

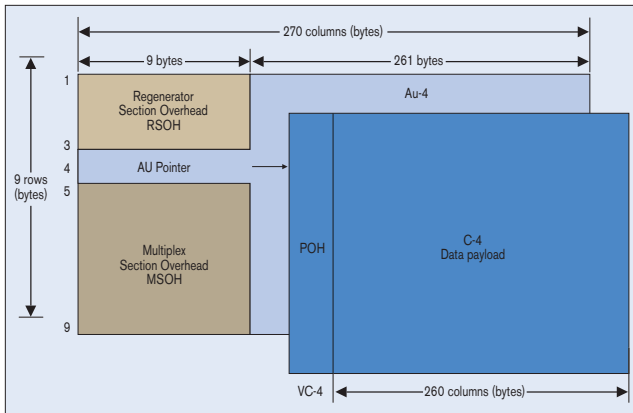

Figure 2.6 STM-1 Frame Format

2.4.2 STM-1 Frame Format

The STM-1 frame is the basic transmission format for SDH. Figure 2.6 illustrates the basic SDH frame structure. The STM-1 frame consists of overhead plus a virtual container payload. The first nine columns of each frame make up the section overhead (SOH), and the last 261 columns make up the virtual container (VC) payload. The VC plus the pointers (H1, H2, and H3 bytes) is called the administrative unit (AU). The VC has its own frame structure of nine rows and 261 columns, and it carries both the path overhead (POH) and the container. The first column is for path overhead, followed by the payload container, which can itself carry other containers. Within the section overhead, the first three rows are used for the regenerator section overhead, and the last five rows are used for the multiplex section overhead.

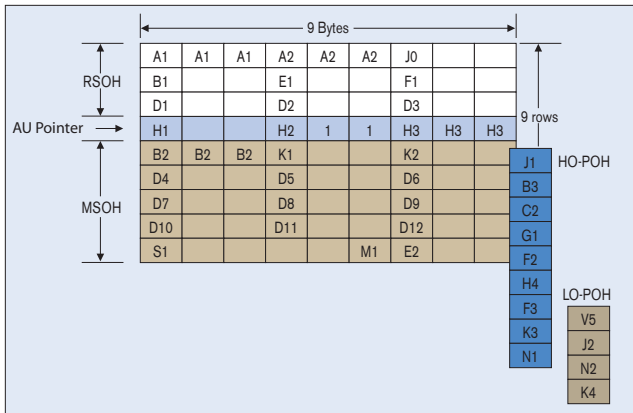

Figure 2.7 SDH Overhead Format

SDH Overhead

The SDH overhead information has several layers (shown in Figure 2.7): the regenerator section overhead, the multiplex section overhead, the high-order path overhead, and the low-order path overhead. The following sections detail the different SDH overhead information:

- Regenerator Section Overhead:** This layer contains only the information required for the elements located at both ends of a section. This might be two regenerators, a line-terminating equipment component and a regenerator, or two line-terminating equipment components. The regenerator section overhead is found in the first three rows of Columns 1 through 9 of the STM-1 frame. Table 2.5 lists the regenerator section overhead bytes and their corresponding functions.

Table 2.5 – Regenerator Section Overhead

Byte	Description
A1 and A2	Framing bytes – These two bytes indicate the beginning of the STM-N frame.
J0	Regenerator section (RS) trace message – It's used to transmit a section access-point identifier so that a section receiver can verify its continued connection to the intended transmitter.
Z0	These bytes are reserved for future international standardization.
B1	RS bit-interleaved parity code (BIP-8) byte – This is a parity code (even parity) used to check for transmission errors over a regenerator section.
E1	RS orderwire byte – This byte is allocated to be used as a local orderwire channel for voice communication between regenerators.
F1	RS user-channel byte – This byte is set aside for the user's purposes; it can be read and/or written at each section terminating equipment in that line.
D1, D2, D3	RS data-communications channel (DCC) bytes – These three bytes form a 192 kbit/s message channel, providing a means of communication between the various parts of section-terminating equipment and thus enabling operations, administration, maintenance, and provisioning (OAM&P).

- **Multiplex Section Overhead:** This layer contains the information required between the multiplex section-termination equipment at each end of the multiplex section (that is, between consecutive network elements, excluding the regenerators). The multiplex section overhead is found in Rows 5 to 9 of Columns 1 through 9 of the STM-1 frame. Table 2.6 lists the multiplex section overhead bytes and their corresponding functions.

Table 2.6 – Multiplex Section Overhead

Byte	Description
B2	Multiplex section (MS) bit-interleaved parity code (MS BIP-24) byte – Provides multiplex section error monitoring. The BIP-N x 24 of an STM-N frame provides end-to-end error performance monitoring across an individual multiplex section and is calculated over all bits of the previous STM-N frame, except for the first three rows of SOH.
K1, K2	Automatic protection switching (APS channel) bytes – These two bytes are used for multiplex section protection (MSP) signaling between multiplex level entities for bidirectional automatic protection switching and for communicating alarm indication signals (AISs) and remote defect indications (RDIs).
D4 to D12	MS data-communications channel (DCC) bytes – These nine bytes form a 576 kbit/s message channel from a central location for OAM information (control, maintenance, remote provisioning, monitoring, administration and other communication needs).
S1	Synchronization status message byte (SSMB) – Bits 5 to 8 of this S1 byte are used to carry the synchronization messages.
M1	MS remote error indication – The M1 byte of an STM-1 or the first STM-1 of an STM-N is used for an MS layer remote error indication (MS-REI).
E2	MS orderwire byte – This orderwire byte provides a 64 kbit/s voice channel between multiplex entities for an express orderwire.

- **Higher-Order Path Overhead (VC-3/VC-4):** The path overhead is assigned to, and transported with, the virtual container from the time it is created by path-terminating equipment until the payload is demultiplexed at the termination point in path-terminating equipment component. The path overhead is found in Rows 1 to 9 of the first column of the VC-4 or VC-3. Table 2.7 lists the higher-order path overhead bytes and their corresponding functions.

Table 2.7 – Higher-Order Path Overhead (VC-3/VC-4)

Byte	Description
J1	Higher-order VC-N path trace byte – This user-programmable byte repetitively transmits a 16-byte or 64-byte free-format string allowing the receiving terminal in a path to verify its continued connection to the intended transmitting terminal.
B3	Path bit-interleaved parity code (Path BIP-8) byte – This is a parity code (even), used to determine if a transmission error has occurred over a path.
C2	Path signal label byte – This byte specifies the mapping type in the VC-N.
G1	Path status byte – This byte is used to convey the path-terminating status and performance back to the originating path-terminating equipment.
F2	Path user-channel byte – This byte is used for user communication between path elements.
H4	Position and sequence indicator byte – This byte provides a multiframe and sequence indicator for virtual VC-3/4 concatenation and a generalized position indicator for payloads.
F3	Path user-channel byte – This byte is allocated for communication purposes between path elements and is payload-dependent.
K3	APS signaling is provided in K3 bits 1-4, allocated for protection at the VC-4/3 path levels. K3 bits 5-8 are allocated for future use.
N1	Network operator byte – This byte is allocated to provide a higher-order tandem connection monitoring (HO-TCM) function.

- **Lower-Order Path Overhead (VC-11/VC-12):** These bytes are allocated to the VC-11/VC-12 POH. Table 2.8 lists the lower-order path overhead bytes and their corresponding functions.

Table 2.8 – Lower-Order Path Overhead (VC-11/VC-12)

Byte	Description
V5	VT path overhead byte.
J2	Used to repetitively transmit a lower-order access path identifier so that a path-receiving terminal can verify its continued connection to the intended transmitter. A 16-byte frame is defined for the transmission of path access-point identifiers. This 16-byte frame is identical to the 16-byte frame of the J1 and J0 bytes.
N2	Allocated for tandem connection monitoring for the VC2, VC-12, and VC-11 level.
K4	Bit 1 is used for multiframe alignment signals and extended signal labels, whereas Bit 2 is used for virtual concatenation.

2.5 Virtual Tributaries/Containers

As mentioned, one of the advantages of the SONET/SDH standard is that it will transport all of the lower-rate signals by mapping them into “sections” of an STS-1 or STM-1 frame, called virtual tributaries in SONET and virtual container in SDH. In SONET, a virtual tributary information is organized inside an STS-1 channel of SONET frames and routed through the network to a specified destination from a given source location. Each of the virtual tributary sections is independent of the others and can carry a different type of payload.

2.5.1 SONET Virtual Tributaries

Currently, there are four virtual tributary sizes defined in SONET:

- VT1.5: Carries enough bandwidth to transport a DS-1 signal of 24 DS-0s at 64 kbit/s. Each is contained in three 9-byte columns (27 bytes). A single VTG can carry 4 VT1.5s.
- VT2: Carries enough bandwidth to transport an E-1, 2.048 Mbit/s signal. It is contained in four 9-byte columns (36 bytes).
- VT3: Carries enough bandwidth to transport a DS-1C signal. It is contained in six 9-byte columns (54 bytes).
- VT6: Carries enough bandwidth to transport a DS-2 signal. It is contained in twelve 9-byte columns (108 bytes).

The different-size tributary options are provided to maximize available bandwidth in an STS-1 channel. For example, if the end user requires the transport of DS-1C signals requiring 3.152 Mbit/s, a size VT3 virtual tributary would be the ideal solution, as opposed to a size VT6, which provides much more bandwidth than what is needed. Other common low-rate signals such as DS1, E1, and DS2 fit into virtual tributary types VT1.5, VT2, and VT6, respectively.

The virtual tributary structure contains three main components consisting of the payload pointer (VT payload pointer), path overhead (VT POH), and payload data bytes. Together, the path overhead and payload data form what is called the VT synchronous payload envelope (SPE). Each virtual tributary type has a unique VT SPE size. Although the number of payload bytes in the VT SPE differs for each virtual tributary size, the number of VT POH bytes and functionality of each is the same, regardless of the VT type.

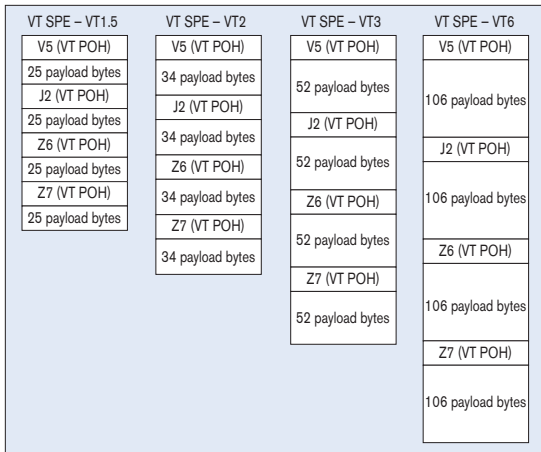

Figure 2.8 SONET Virtual Tributary Structures

Figure 2.8 illustrates four VT POH bytes contained in any VT structure separated by a fixed number of payload bytes. The first byte of the VT SPE is always the V5 VT POH byte. V5 is used to provide tributary BIP-2 parity (provides error performance monitoring), REI-V (remote error indication used to indicate BIP-2 errors at originating equipment), RFI-V (remote failure indication), signal label (indicates content of VT SPE), and RDI-V (remote defect indication) information.

2.5.2 SDH Virtual Tributaries

SDH, on the other hand, supports a concept called virtual containers (VC). Through the use of pointers and offset values, VCs can be carried in the SDH payload as independent data packages. VCs are used to transport lower-speed tributary signals. A basic SDH frame has a capacity of 155 Mbit/s, which means that it can either transport one VC-4 virtual container or three VC-3 virtual containers. The payload of each of these containers can be one high-rate tributary or a combination of tributary unit groups that contain low-rate signals.

As for low-speed signals, VC-12 (and, likewise, VC-2 and VC-11) must be transported in other containers with a greater capacity (VC-3 or VC-4) before being introduced in the STM-1 frame. The containers with a greater capacity can transport up to 63 VC-12s in the STM-1 frame. The VC-4 container has 63 pointers that find the location of each of the VC-12s transported with respect to the VC-4. The following are the currently defined virtual container sizes in the SDH standard:

- VC-11: Carries enough bandwidth to transport 1.728 Mbit/s. Each is contained in 9 rows, 3 columns (27 bytes).
- VC-12: Carries enough bandwidth to transport 2.304 Mbit/s. Each is contained in 9 rows, 4 columns (36 bytes).
- VC-2: Carries enough bandwidth to transport 6.912 Mbit/s. Each is contained in 9 rows, 12 columns (108 bytes).
- VC-3: Carries enough bandwidth to transport 48.960 Mbit/s. Each is contained in 9 rows, 85 columns (765 bytes).
- VC-4: Carries enough bandwidth to transport 150.336 Mbit/s. Each is contained in 9 rows, 261 columns (2,349 bytes).

3

Why Next-Generation SONET/SDH?

3. Why Next-Generation SONET/SDH?

Simply stated, next-generation SONET/SDH has gained a significant momentum in the industry as its associated technologies have allowed SONET/SDH to evolve with the times and offer an efficient means of transporting packet-based services over the widely deployed SONET/SDH networks.

As described above, SONET/SDH standards have their roots in the multiplexing and transport of voice channels, as well as private line ATM and Frame Relay services; therefore, they have not been designed to transport data services such as Ethernet, resulting in several limiting factors when attempting to transport packet-based services:

SONET/SDH transport rates are not ideally suited for transporting packet interfaces such as Ethernet and Fibre Channel: The lowest data rate that can be carried on SONET is 1.544 Mbit/s. Slower rates can be carried, but it requires tying up the entire bandwidth capacity; i.e., 1.544 Mbit/s. The rates go up from there (approximate values): 2 Mbit/s, 3 Mbit/s, 6 Mbit/s, 34 Mbit/s, 45 Mbit/s, 139 Mbit/s, 155 Mbit/s, 622 Mbit/s, 2.5 Gbit/s, and 10 Gbit/s. Rates between those values could only be carried by using the next higher bandwidth, an inefficient arrangement. For example, Gigabit Ethernet circuits (at a bandwidth of 1 Gbit/s) can only be carried on 2.5 Gbit/s, thus wasting over half the available bandwidth.

SONET/SDH has no built-in capability for dynamically shifting bandwidth usage: In order to efficiently use bandwidth, it can be very advantageous to shift usage based on time of day or other factors. For example, a financial institution may need bandwidth only during business hours. If the organization were connected directly to a SONET/SDH circuit, that bandwidth would be tied up all the time, even during nights and weekends.

SONET/SDH has no common data mapping scheme: Frame Relay, ATM, and Packet-over-SONET (PoS) are the dominant service-layer technologies for data service delivery over traditional SONET/SDH networks. More recently, Ethernet over LAPS (also known as X.86) has emerged for Ethernet service delivery over SONET/SDH networks. The common issue with these technologies is that they are client-service-specific, and do not represent a common traffic adaptation scheme for a wide range of data services (i.e., Ethernet, Fibre Channel, IP/PPP, etc.).

As mentioned earlier, Ethernet has become the Layer 2 technology of choice for both enterprise connectivity and access aggregation networks. As service providers had invested heavily in their SONET/SDH networks and they found the technology to be reliable, there was great incentive to keep using the existing infrastructure to meet Ethernet demand.

As a consequence, in 1999, work was initiated within the ITU-T & ANSI standards bodies to define technologies that would help SONET/SDH evolve with the times and offer efficient means of transporting these packet-based services over the widely deployed SONET/SDH networks. Their answer: the definition and ratification of three key technologies that form the basis of next-generation SONET/SDH: generic framing procedure (GFP), virtual concatenation (VCAT), and link-capacity-adjustment scheme (LCAS).

The following sections provide an in-depth look into these three key next-generation SONET/SDH technologies, outlining their key applications in next-generation networking.

4

Generic Framing Procedure (GFP)

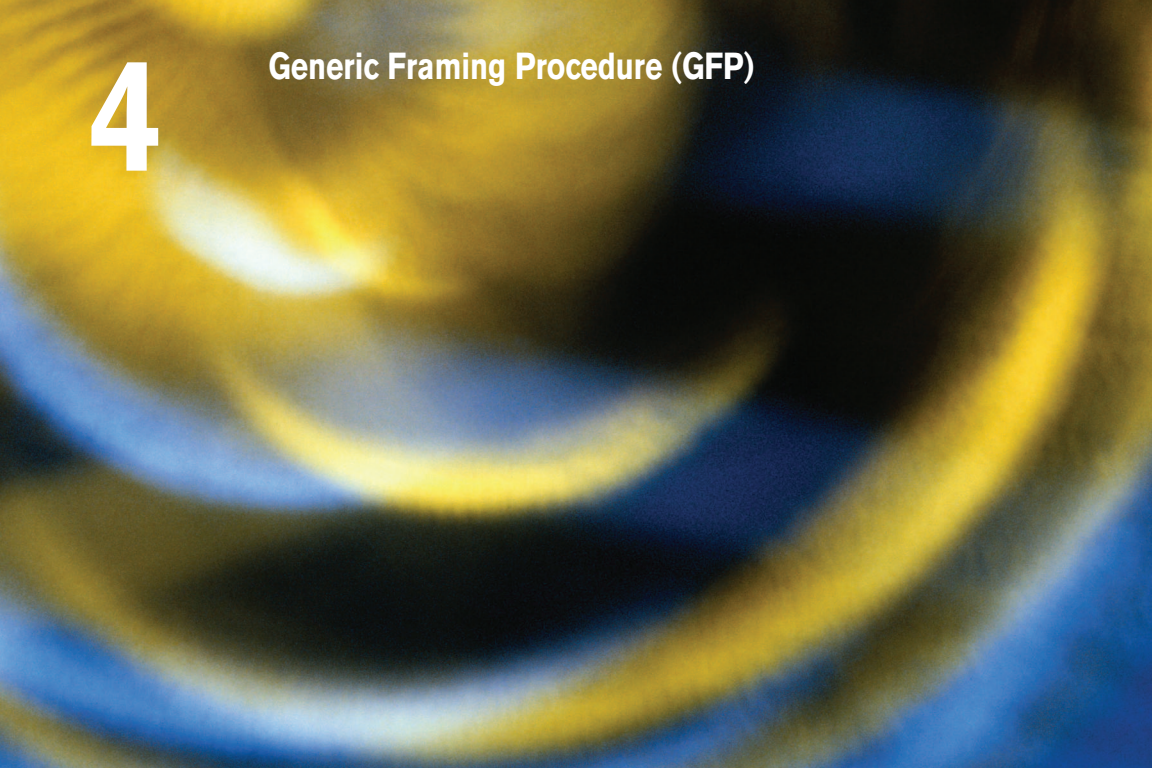

4. Generic Framing Procedure (GFP)

Generic framing procedure (GFP), defined in ITU recommendation G.7041/Y.1303, is a framing mechanism to transport packet-based client signals, such as Ethernet, Fibre Channel, ESCON, FICON, over fixed-data-rate optical channels. As such, GFP provides a single, flexible mechanism to map these client signals into SONET/SDH and OTN networks, as shown in Figure 4.1 below.

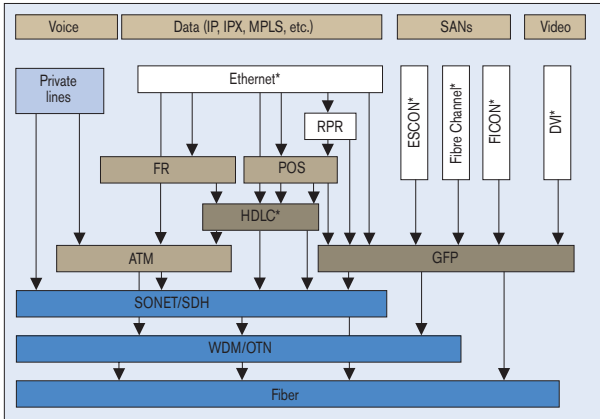

Figure 4.1 Client Signal Mapping over GFP

Prior to the introduction of GFP, several methods had been used to transport packet services over SONET/SDH networks. The first method was Asynchronous Transfer Mode (ATM) Adaptation Layer 5 (AAL 5) over SONET/SDH. ATM is a very efficient switching and multiplexing technology, whose transfer rates scale with SONET/SDH rates. However, ATM does not make the most efficient use of bandwidth because the payload data is separated into groups of 48 bytes, called cells, with an additional 5-byte header of software overhead. It became immediately apparent that almost 10% of the bandwidth would be lost. In addition, certain types of data required even more ATM overhead.

Other methods have focused on using point-to-point protocol (PPP). The IP traffic coming to an Ethernet port is encapsulated over a PPP link and multiple ports can be encapsulated over multilink PPP (ML-PPP) links. By using an HDLC framing, the PPP traffic is transported over the SONET/SDH payload. These methods have been standardized within the IETF through the following Requests

for Comments (RFC): RFC 1662, RFC 1990 and RFC 2615. The ITU-T expanded this work by specifying the use of LAPS (very similar protocol to PPP/HDLC) and specifying IP over LAPS in X.85/Y.1321 and Ethernet over LAPS in X.86/Y1323. All these methods for encapsulating traffic suffer from the weaknesses of HDLC framing; i.e., limited protection from frame corruption and the introduction of variable packet sizes because of its trailer.

GFP has been standardized to better optimize the transport of Ethernet and other data services over SONET/SDH networks, taking into account both the pros and cons of ATM and PPP/HDLC and leveraging two new emerging SONET/SDH capabilities, VCAT and LCAS, that will be discussed later in this document.

4.1 GFP Mapping

Two types of mapping are currently available for GFP: framed-mapped (GFP-F) and transparent-mapped (GFP-T), whose mappings keep the same basic frame structure, as will be shown in the next sections. The decision on which mode to use is dependent on the underlying service to be transported.

— **Frame-Mapped GFP (GFP-F)** is mapping mechanism in which one client signal frame is received and mapped in its entirety into one GFP frame. Therefore, with this adaptation mode, the GFP-F frame size is variable as it is directly related to the incoming client payload. In fact, with GFP-F, the entire client frame must be buffered in order to determine its length. GFP-F is usually used to support Layer 2 frames like Ethernet MAC that are tolerant to some latency. The ITU G.7041 defines the following frame-mapped user payloads supported through GFP-F:

- Frame-Mapped Ethernet
- Frame-Mapped PPP
- Frame-Mapped Multiple Access Protocol over SDH (MAPOS)
- Framed-Mapped IEEE 802.17 Resilient Packet Ring
- Frame-Mapped Fibre Channel FC-BBW

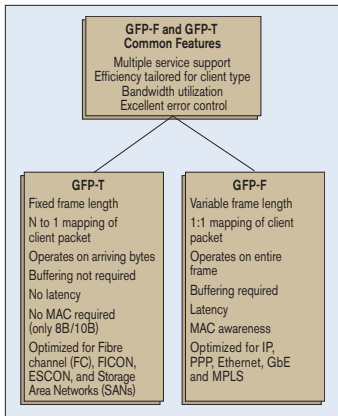

Figure 4.2 GFP-T vs. GFP-F Features

— **Transparent-Mapped GFP (GFP-T)** is a mapping mechanism that facilitates the transport of 8B/10B block-coded client signals like Gigabit Ethernet (GbE), Fibre Channel, ESCON, FICON, and DVB-ASI. With GFP-T, individual characters of a client signal are decoded from the client signal and then mapped into fixed-size GFP frames (64B/65 coded superblocks). This approach avoids the buffering of an entire client frame before it can be mapped into a GFP frame, which reduces latency and in turn makes it ideally suited for SAN applications that require very low transmission latency.

Figure 4.2 provides a functional comparison between GFP-F and GFP-T, while Figure 4.3 provides a comparison of the GFP frames for both modes.

Functionally, GFP consists of both common and client-specific aspects. Common GFP aspects apply to all GFP-adapted traffic (i.e., both GFP-F and GFP-T) and cover functions such as packet data unit (PDU) delineation, data link synchronization and scrambling, client PDU multiplexing, and client-independent performance monitoring. Client-specific aspects of GFP cover issues such as mapping of the client PDU into the GFP payload, client-specific performance monitoring, as well as operations, administration, and maintenance (OA&M). This is illustrated in Figure 4.1.

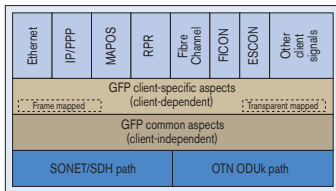

Figure 4.3 GFP-T vs. GFP-F Frames

4.2 GFP Frame Structure

As illustrated in Figure 4.4, two basic GFP frame types have been defined: GFP client frames and GFP control frames. GFP client frames are categorized into two types: client data frames (CDFs) and client management frames (CMFs). CDFs are used to transport the client data, while CMFs are used to transport information associated with the management of the client signal or GFP connection.

As for GFP control frames, at this time, only one category has been defined by the standard so far; i.e., GFP idle frames.

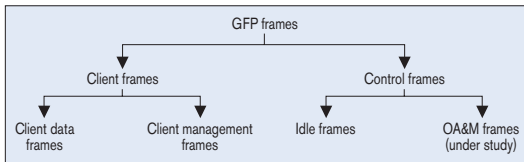

Figure 4.4 GFP Frames Types

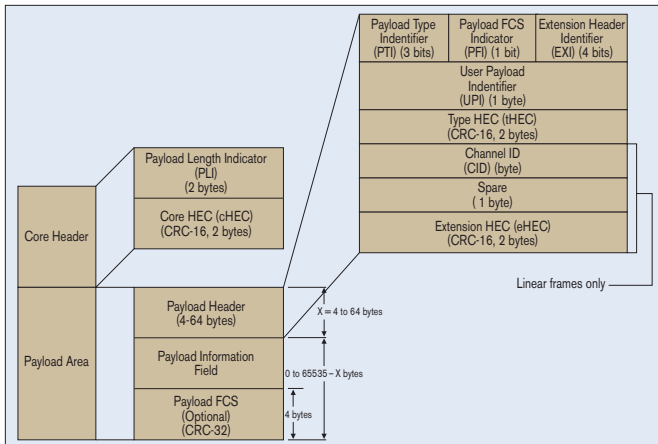

Figure 4.5 GFP Generic Frame Structure

The GFP generic frame structure is presented in Figure 4.5.

Each GFP frame type consists of three main components: the core header, the payload header, and the payload information field.

The core and payload headers form the GFP header, whereas the payload information field represents the customer traffic carrying the data services. The payload header carries information about the payload type (i.e., Ethernet, Fibre Channel, etc.) that it is carrying, while the core header carries information about the size of the GFP frame itself.

Each header contains a header error correction (HEC) calculation, allowing for the correction of single errors; that is, any errors that occur in the core header or in the payload header can potentially be corrected by the HEC, through the network element. This creates a very robust mapping scheme, which ensures that GFP frames can get transported across a network without customer traffic loss.

Core Header

The GFP core header consists of a two-octet length field, specifying the length of the GFP frame's payload area in octets, and a two-octet field containing a CRC-16 error-check code.

- **Payload Length Indicator (PLI):** The PLI is a two-byte field indicating the size in bytes of the GFP payload area. It indicates the beginning of the next GFP frame in the incoming bit-stream as an offset from the last byte in the current GFP core header. PLI values in the range of 0 to 3 are reserved for GFP internal use and are referred to as GFP control frames. All other frames are referred to as GFP client frames.
- **Core HEC (cHEC):** The cHEC is a two-byte field containing a cyclic redundancy check (CRC-16) sequence that protects the integrity of the core header. The cHEC sequence is computed over the core header bytes using standard CRC-16. The CRC-16 enables both single-bit error correction and multibit error detection.

Payload Header

The payload header is a variable-length area, 4 to 64 octets long, intended to support data-link management procedures specific to the transported client signal. The payload header contains two mandatory fields, the Type field and Type Header Error Correction (tHEC) field. The payload header also supports an additional variable number of subfields referred to, as a group, as the extension header.

- **Payload Type Identifier (PTI):** A three-bit subfield that identifies the type of GFP client frame. Table 4.1 lists the currently defined user frames.

Table 4.1 – Payload Type Identifier Types and Description

PTI	Description
000	Client Data Frame
100	Client Management Frame
Others	Reserved

- **Payload FCS Indicator (PFI):** A one-bit subfield indicating the presence (1) or absence (0) of the payload FCS field. Table 4.2 lists the currently defined PFI values.

Table 4.2 – Payload FCS Indicator Values and Description

PFI	Description
0	FCS Absent
1	FCS Present

- **Extension Header Identifier (EXI):** A four-bit subfield identifying the type of GFP extension header. Three kinds of extension headers are currently defined.

Table 4.3 – Extension Header Identifier Values and Description

EXI	Description	Function
0000	Null Extension Header	Indicates that no extension header is present.
0001	Linear Extension Header	A two-octet extension header that supports sharing of the GFP payload across multiple clients in a point-to-point configuration. The linear extension header consists of an eight-bit channel ID (CID) field, used to indicate one of 256 communication channels (i.e. clients) at a GFP termination point, and an eight-bit spare field reserved for future use.
0010	Ring Extension Header	The use of this field is under consideration. Similar to linear, the current proposal being considered is to allow the sharing of the GFP payload across multiple clients; however, this would only apply to ring configurations.
From 0011 to 1111	Reserved	

- **User Payload Identifier (UPI):** An eight-bit field identifying the type of payload conveyed in the GFP payload information field:

Table 4.4 – User Payload Identifier (UPI) Values and Description

UPI	Client Data	Client Management
0000 0000 1111 1111	Reserved and not available	Reserved
0000 0001	Mapped Ethernet Frame	Client Signal Fail (Loss of Client Signal)
0000 0010	Mapped PPP Frame	Client Signal Fail (Loss of Character Synchronization)
0000 0011	Transparent Fibre Channel	Reserved for future use
0000 0100	Transparent FICON	
0000 0101	Transparent ESCON	
0000 0110	Transparent GbE	
0000 0111	Reserved for future use	
0000 1000	Frame-Mapped IEEE 802.17 Resilient Packet Ring	
0000 1011	Frame-Mapped Fibre Channel FC-BBW	
0000 1100	Asynchronous Transparent Fibre Channel	
0000 1101 through 1110 1111	Reserved for future standardization	
1111 0000 through 1111 1110	Reserved for proprietary use	

- **Type HEC (tHEC) Field:** A two-octet field that contains a CRC-16 sequence to protect the integrity of the type field. The tHEC sequence is computed over the core header bytes using standard CRC-16. As with the cHEC, CRC-16 enables both single-bit error correction and multibit error detection.
- **Channel Identifier (CID):** A one-byte field that is only available when the EXI field is configured to Linear. The CID byte is used to indicate one of 256 communication channels at a GFP termination point.

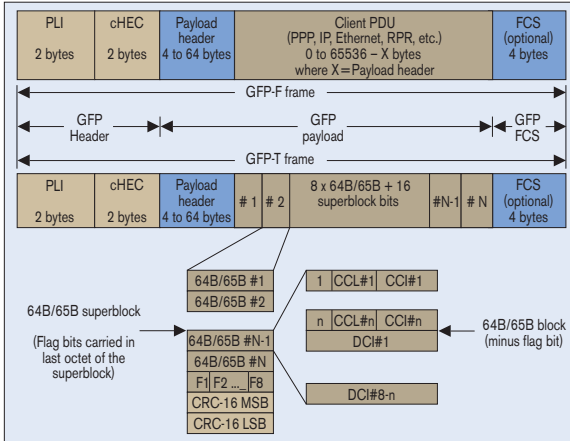

Figure 4.6 GFP-F vs. GFP-T Frame Structure

- **Spare:** A one-byte field that is only available when the EXI field is configured to Linear. This field is reserved for future use.
- **Extension HEC (eHEC):** A two-byte field that contains a CRC-16 check sequence that protects the integrity of the contents of the extension. CRC-16 enables both single-bit correction and multibit error detection.

Figure 4.6 explains how (in GFP-F) the transmitter encapsulates one entire frame of the client data.

■ Payload Information Field

The payload area (also referred to as payload information field) contains the framed client signal. This variable-length field may include from 0 to 65,535 - X octets, where X is the size of the payload header (including the extension header, if present) and the payload FCS field (if present).

Figure 4.3 above shows the GFP-T and GFP-T frame structures. As shown, both frame types share a common core header, payload header, and payload FCS (optional), and they differ in the way in which the client is mapped into this payload area.

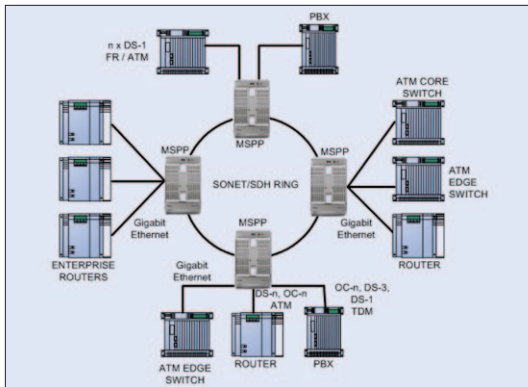

Figure 4.7 Multiservice SONET/SDH Network

4.3 GFP Summary

GFP has been standardized to better optimize the transport of Ethernet and other data services over SONET, taking into account both the pros and cons of ATM and PPP/HDLC framing mechanisms. As described in this section, GFP represents a robust mapping mechanism that allows for the mapping of multiple client-data types into SONET/SDH payload (SPEs). This technology has been embraced by network equipment and service providers as it provides an efficient way of providing interoperable data-services transport over the existing SONET/SDH install base. The versatility provided by GFP allows SONET/SDH networks to offer transport services for a multiple of services, as shown in the adjacent figure.

That being said, the answer to a truly efficient packet-transport mechanism comes via the combination of GFP and a bandwidth-optimizing technology such as VCAT or LCAS, as we will see in the next sections.

- Payload FCS (pFCS):** This is an optional four-octet-long frame-check sequence. It contains a CRC-32 check sequence that is designed to validate the entire content of the payload area. The FCS field presence is signaled by the PFI bit located in the Type field of the payload header. The FCS does not correct any errors; it just indicates the presence of error(s).

In GFP-F, the transmitter encapsulates one entire frame of the client data into one GFP frame. In this case, the basic frame structure of a GFP client frame is used, including the required payload header.

In GFP-T, however, rather than buffering an entire client-data frame, the individual characters of the client signal are demapped from the client block codes and then mapped into periodic fixed-length GFP frames. The transparent GFP client frame uses the same structure as the frame-mapped GFP, including the required payload header.

5

Virtual Concatenation (VCAT)

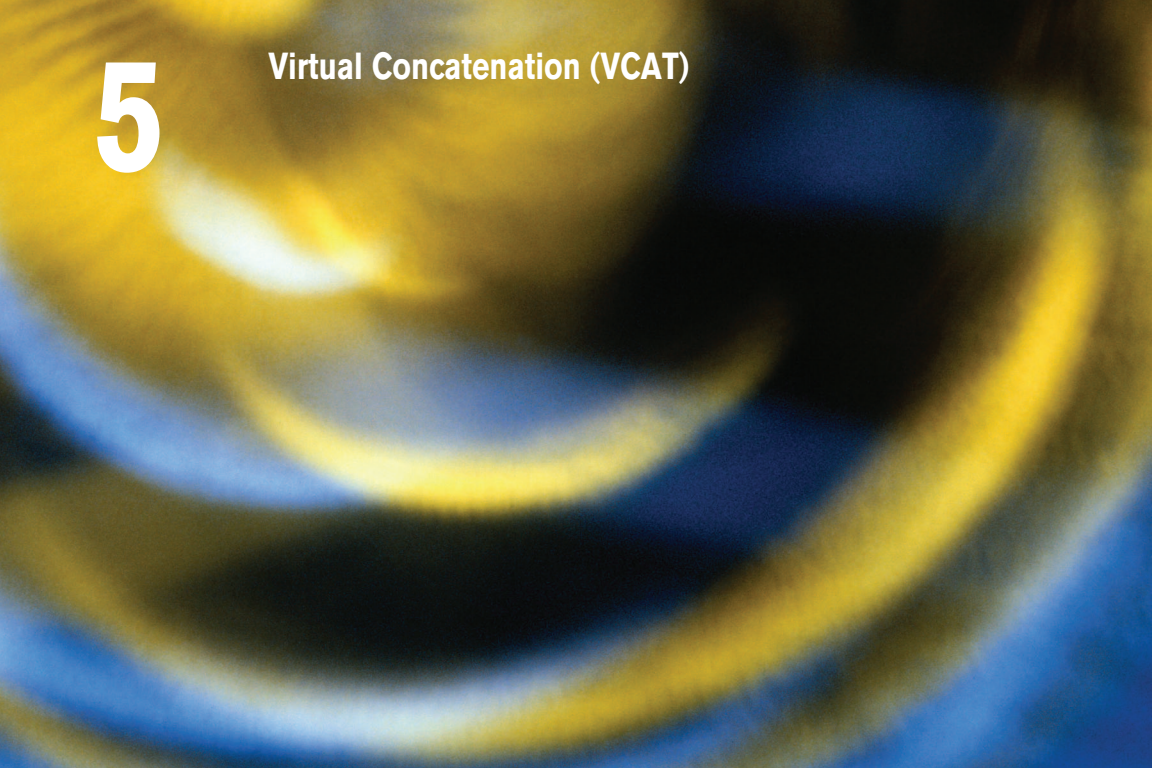

5. Virtual Concatenation (VCAT)

As described in Chapter 3, SONET/SDH multiplexing combines low-speed digital signals (DS1, DS2, DS3 for SONET; E1, E3, and E4 for SDH) with the required overhead to form building-block frames called STS-1 SPE (SONET) and STM-1 (SDH). To enable higher-bandwidth transport than these basic rates allow individually, multiple SPEs can be combined and transported across the SONET/SDH network as a single connection, with the first SONET container payload pointer set to normal mode and the subsequent payload pointers set to concatenation mode, thus linking all the units together.

Table 5.1 outlines supported contiguous concatenation for both SONET and SDH. For the SONET standard, these are denoted as STS-Xc, and for SDH as VC-4-Xc.

Table 5.1 – Contiguous Concatenation Containers for SONET and SDH

SONET	SDH	Payload Capacity (Mbit/s)
STS-1	VC-3	48.38
STS-3c	VC-4	149.76
STS-12c	VC-4-4c	599.04
STS-48c	VC-4-16c	2,396.16
STS-192c	VC-4-64c	9,584.64
STS-768c	VC-4-256c	38,486.016

As described in Chapter 2, lower-rate virtual tributary signals have also been defined for both SONET and SDH, as shown in the table below:

Table 5.2 – Tributary Units for SONET and SDH

SONET	SDH	Payload Capacity (Mbit/s)
VT 1.5	VC-11	1.6
VT 2	VC-12	2.17
VT 6	VC-2	6.78

Although contiguous concatenation has been successfully introduced and deployed for years, it poses some major deficiencies when attempting to transport packet-based signals. First, in contiguous concatenation, the concatenated bandwidth requires the timeslots to be consecutive. Second, it also requires that the network elements involved in the transport of the traffic support this function from the source to the destination node, including every intermediate node. Third, data-service rates are not well matched to these defined containers, hence using GFP with current contiguous concatenation schemes results in sub-optimal use of the bandwidth, as Ethernet and Fibre Channel data rates are not properly matched to these channels (e.g., 100M Ethernet service mapped over an STS-3c or VC4 results in approximately 33% of wasted bandwidth).

To address these limitations, a complementary technology – virtual concatenation (VCAT) – was developed and later defined in ANSI T1.105, ITU G.707, and ITU G.783 recommendations. Two forms of virtual concatenation were defined; i.e., high-order and low-order VCAT. This introduced additional flexibility to SONET/SDH by allowing for the non-contiguous concatenation of high-order or low-order payload frames to better scale the requirements for incremental client-data streams. This means that the concatenated payload does not need to be formed by consecutive timeslots in the transport path. In addition, this new concatenation capability allows the network element involved in the transport of the traffic to be unaware of concatenated nature of the signal. As such, only the termination points in the transport path must support the VCAT functionality.

In essence, virtual concatenation is an inverse multiplexing procedure whereby the contiguous bandwidth is broken into individual SPEs at the source transmitter and logically represents them in a virtual concatenation group (VCG). Control packets, which contain the necessary information for reassembling the original data stream at its destination PTE, are inserted in some of the currently unused SONET/SDH overhead bytes (H4 byte for high-order, and Z7 (SONET) and K4 (SDH) for low-order). This information contains the sequence order of the channels and a frame

number, which is used as a time stamp. The VCG members are transported as individual SPEs across the SONET/SDH network with all the intelligence required to handle virtual concatenation located at the end points of the connections (i.e., at the path termination equipment, or PTE). The receiving end-point (PTE) is responsible for reassembling the original byte stream. This allows SONET/SDH channels to be routed independently through the network without requiring any acknowledgement of the virtual concatenation. In this manner, virtually concatenated channels may be deployed on the existing SONET/SDH network with a simple end-point node upgrade.

As presented in the table below, VCAT provides a much more efficient use of the transport bandwidth for data user interfaces. With VCAT, an OC-48 link can carry two full Gigabit Ethernet signals with 95% of the link used through seven virtual STS-3c/VC-4s each, instead of just one Gigabit Ethernet signal with 42% of the link used through an STS-48c/AU-4-16c.

Table 5.3 – Bandwidth Efficiency Using Virtual Concatenation

Service	Bit Rate	Utilization Without VCAT	Utilization with VCAT
Ethernet	10 Mbit/s	STS-1/V-3 (20%)	VT1.5-7v (89%)/VC12-5v (92%)
Fast Ethernet	100 Mbit/s	STS-3c/VC-4 (67%)	STS-1-2v/VC-3-2v (100%)
Gigabit Ethernet	1000 Mbit/s	STS-48c/VC-4-16c (42%)	STS-3c-27v/VC-4-7v (95%)
Fibre Channel	200 Mbit/s	STS-12c/VC-4-4c (33%)	STS-1-4v/VC-3-4v (100%)
Fibre Channel	1000 Mbit/s	STS-48c/VC-4-16 (42%)	STS-3c-27v/VC-4-7v (95%)
ESCON	200 Mbit/s	STS-12c/VC-4-4c (33%)	STS-1-4v/VC-3-4v (100%)

In summary, virtual concatenation enables SONET/SDH transport pipes to be filled more efficiently with data services by grouping individual SONET/SDH containers into a virtual high-bandwidth “link”, matched to the required service bandwidth. The following sections will provide a more in-depth look at the inner workings of high-order and low-order VCAT frame structures.

5.1 High-Order Virtual Concatenation (HO VCAT)

HO VCAT provides bandwidth for links that require speeds greater than 51.84 Mbit/s, but do not lend themselves to one of the standard contiguous concatenation bandwidth configurations. HO VCAT is realized under SONET and SDH by the PTE, which combines either multiple STS-1/STS-3c SPEs (for SONET) or VC-3/VC-4s (for SDH), therefore making it ideally suited for transport of 100M, Gigabit Ethernet, and Fibre Channel rates.

HO VCAT rates are designated by STS-m-nv or VC-m-nv, where the *nv* indicates a multiple *n* of the STS-m/VC-m base rate.

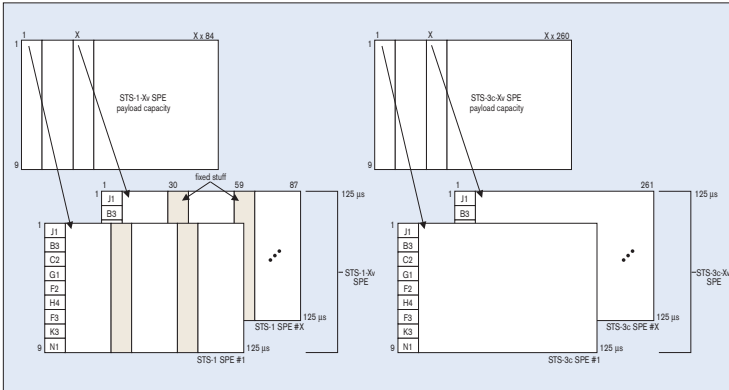

Figure 5.1 STS-1/3c-Xv VCG

5.1.1 HO VCAT Frame Structure

As mentioned, a HO VCG super-container can be formed by using STS-1 or STS-3c in SONET and VC-3 (AU-3) or VC-4 (AU-4) in SDH. This means that a SONET virtually concatenated payload STS-1/3c-Xv or an SDH VC-3/4-Xv can transport $X \cdot 48384/149760$ kbit/s, as shown respectively in Figure 5.1 and Figure 5.2, assuming the stuff bytes remain untouched.

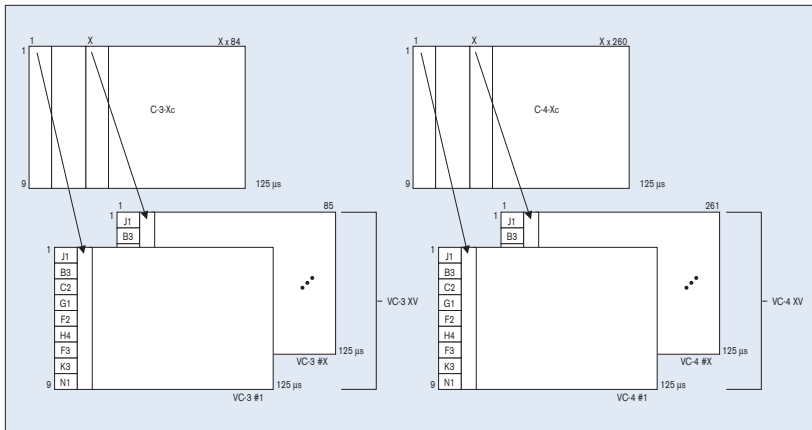

Figure 5.2 VC-3/4-Xv

In either case, the value of X can be between 1 and 256. Each SONET SPE or SDH VC used to create a VC contains its individual path overhead (POH). Among these bytes is the H4 byte, used to specify the virtual concatenation multiframe indicator (MFI) and sequence indicator (SQ).

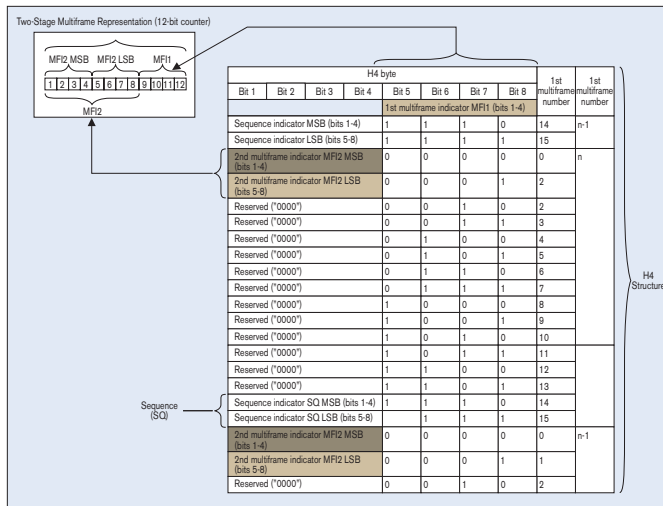

Figure 5.3 H4 High-Order Path Multiframe Structure

5.1.2 HO VCAT Multiframe Indicator (MFI)

As illustrated in Figure 5.3, a two-stage multiframe mechanism is used to cover differential delays of 0 μ s to 256 ms. The two stages can be functionally represented by a 12-bit counter. In the H4 structure, Bits 5 to 8 of H4 bytes are used to form Multiframe Indicator Stage 1 (MF1). MF1 is incremented for every basic frame and counts from 0 to 15. Multiframe Indicator Stage 2 (MF2) is an eight-bit counter based on Frame 0 (bits 1 to 4) and Frame 1 (bits 5 to 8). MF2 is incremented once every time MF1 completes a cycle from 0 to 15. MF2 counts from 0 to 255. The result is a two-stage multiframe process that yields a total of 4096 frames ($16 \times 256 = 4096$) per 512-ms cycle ($4096 \times 125 \mu\text{s} = 512 \text{ ms}$).

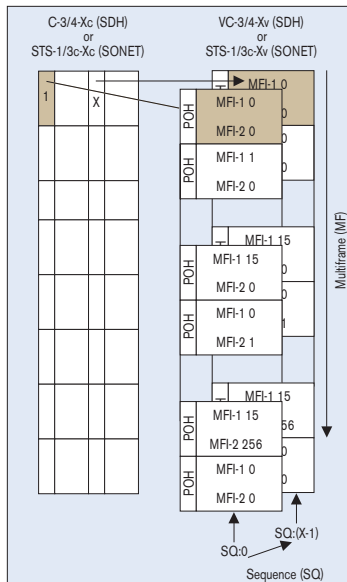

Figure 5.4 Sequence Indicator in High-Order Path VCAT Multiframe

5.1.3 High-Order Path Sequence Indicator

In addition to the MFI, the H4 byte also carries the sequence indicator information. The sequence indicators are assigned by the source node (PTE) and interpreted by destination node (PTE). The sequence indicator (SQ) identifies the order in which the STS-1/STS-3c of a SONET STS-1/STS-3c-Xv is assembled to create the contiguous container (STS-1/STS-3c-Xc), as demonstrated in Figure 5.4. Similarly, SQs are used to identify the order of VC-3/VC-4s used to create the VC-3/4-Xc in SDH.

The eight-bit SQ, supporting a range from 0 to 255, is formed by using the H4 bytes (bits 1 to 4 of frame 14 and 15) in the first multiframe stage (MFI1), as shown in Figure 5.3. Each VCG member is assigned an SQ. Normally, the first timeslot associated to a VCG, composed of STS-1/3c-Xv or VC-3/4-Xv, is assigned number 0, the second one is assigned number 1, and so on for the remainder of the VCG, up to X-1. So, for a STS-1-21v the sequence indicator would go from 0 to 20.

In the event that the terminating equipment is unable to recover the frame or the sequence, or if there is too much differential delay, the system is equipped to generate alarms (LOA and LOS) to the management system to highlight these conditions.

5.2 Low-Order Virtual Concatenation (LO VCAT)

LO VCAT provides bandwidth for links that require speeds greater than 1.6 Mbit/s (VT 1.5/VC-12), but less than 51.84 Mbit/s. LO VCATs are designated by VT-1.5/2/6-nv for SONET and VC-11/12-nv for SDH.

LO VCAT is typically used for sub-rate 10M, sub-rate 100M, and 100 Mbit/s Ethernet data services.

5.2.1 LO VCAT Frame Structure

As described above, low-order paths are used to form VCGs to transport payloads that do not efficiently fit into HO VCAT STS-1/3c or SDH VC-3/VC-4 containers. These LO VCAT payloads are defined in Table 1.

Table 5.4 – Low-Order Path Container Types

SONET	SDH	RATE	CAPACITY
VT1.5	VC-11	1600 kbit/s	1600 to 102400 kbit/s
VT2	VC-12	2176 kbit/s	2176 to 139264 kbit/s
VT3	-	3328 kbit/s	3328 to 212992 kbit/s
VT6	VC-2	6784 kbit/s	6784 to 434176 kbit/s

A VCG can be created by using the SONET VT_n-X_v or the SDH VC-11/12-X_v, where the value of X can range between 1 and 64 (see Figure 5.5 and Figure 5.6).

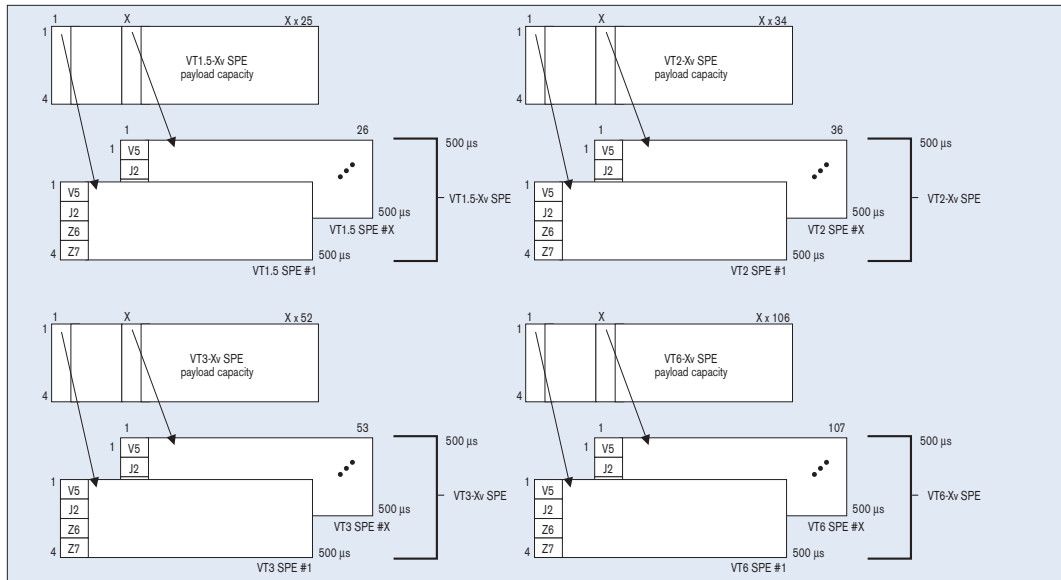

Figure 5.5 SONET VTn-Xv

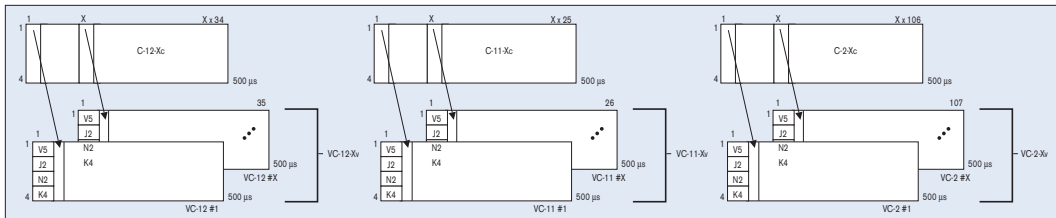

Figure 5.6 SDH VC-n-Xv

To define its multiframe, LO VCAT uses a similar concept as that described above for HO VCAT groups. For the LO VCGs, low-order path overhead bytes Z7 (bit 2) [SONET] and K4 (bit 2) [SDH] are used to support the multiframe structure and specify the MFI and SQ values.

5.2.2 LO VCAT Multiframe and Sequence Indicator (SQ)

Bit 2 of Z7/K4 is used to convey LO VCAT information. It forms a serial string of 32 bits (over 32 four-frame multiframes), as defined in ANSI T1.105 [19] and ITU G.707 (see Figure 5.7). This string is repeated every 16 ms (32 bits x 4 x 125 s/bit) or every 128 frames. This process is repeated until the frame count reaches 32. This means that the total number of frames for a full cycle is 128 frames x 32 = 4096 frames.

The following fields define the frame:

- Frame count is contained in Bits 1 to 5 of the 32-bit string.
- The sequence indicator is contained in Bits 6 to 11 of the 32-bit string.
- The remaining bits (12 to 32) are reserved for other applications. These bits must be set to 0 and must be ignored by the receiver when VCAT is activated without LCAS.

The entire cycle is provided by a frame count that is divided into 32 steps of 16 ms, yielding a total of 512 ms for the length of the multiframe.

The sequence indicator identifies the sequence or the order in which the individual VTn or VC-n of the VTn-Xv or VC-n-Xv is assembled to form the contiguous container VTn-Xc or VC-n-Xc, as displayed in Figure 5.5 and Figure 5.6, respectively. Each member of the VCG has a fixed unique sequence indicator in the range of 0 to (X-1). The sequence indicator for the first VTn or VC-n within the VCG is 0, while the second VTn or VC-n uses sequence indicator 1, and so on up to the last member (SQ = X-1).

In the event that the terminating equipment is unable to recover the frame or the sequence, or if there is too much differential delay, the system is equipped to generate alarms to the management system to highlight these conditions.

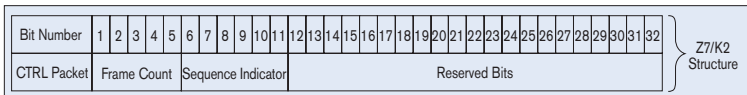

Figure 5.7 LOP Z7/K4 Bit 2 Multiframe Structure

5.3 VCAT Differential Delay

VCAT payload can be split and sent along different paths through the network. Therefore, it is entirely possible that these different paths will not cover the same distance and may contain a different number of network elements along their route. This would mean that members of the VCG do not reach the termination point (end PTE) at the same time. In order for the terminating equipment to reassemble the payload, it must be able to compensate for the difference in payload arrival times. This arrival time difference is known as the differential delay.

Differential delay is the relative arrival time measurement between the members of a VCG. This means that in a next-generation SONET/SDH network, buffering is required at the terminating end of a VCG connection in order to realign the data stream. For high-order VCAT paths, the differential delay is measured by examining the multiframe indicator (MFI) present in the path overhead of each VCG member. For low-order VCAT paths, the frame-count information is used to determine differential delay.

The VCAT standards define the maximum differential delay between members of a VCG to be 256 ms. However, given the amount of buffering required at the terminating points, it is often the case that next-generation SONET/SDH PTEs support less than this maximum, hence making VCAT testing an important consideration when verifying the performance of these network elements.

5.4 VCAT Summary

In short, virtual concatenation provides a means of creating “right-sized” SONET/SDH containers that better match the bandwidth requirements of data client signals such as Ethernet and Fibre Channel. In addition, the flexible nature of VCAT allows service providers to create these right-sized pipes from the unused bandwidth/timeslots present in their network.

All the intelligence needed to create and handle a virtual concatenation is located at the end points of the connections (i.e., at the PTEs). The receiving end-point PTE is responsible for reassembling the original byte stream. This allows SONET/SDH channels to be routed independently through the network without requiring any acknowledgement of the virtual concatenation. In this manner, virtually concatenated channels may be deployed on the existing SONET/SDH network with a simple end-point upgrade.

6

Link-Capacity Adjustment Scheme (LCAS)

6. Link-Capacity Adjustment Scheme (LCAS)

LCAS, as defined per ITU-T recommendation G.7042, is a complementary technology to virtual concatenation. LCAS allows for the dynamic changing of the size of a VCAT group. To do so, signaling messages are exchanged within the same SONET/SDH overhead bytes used for VCAT (H4 for HO VCAT and Z7/K4 for LO VCAT) between the source PTE to the end-point PTE in order to change the number of tributaries being used by a virtually concatenated group (VCG). For example, the number of tributaries can be increased or decreased in response to an identified change in service-bandwidth requirement, or in response to a fault condition of an existing VCG member.

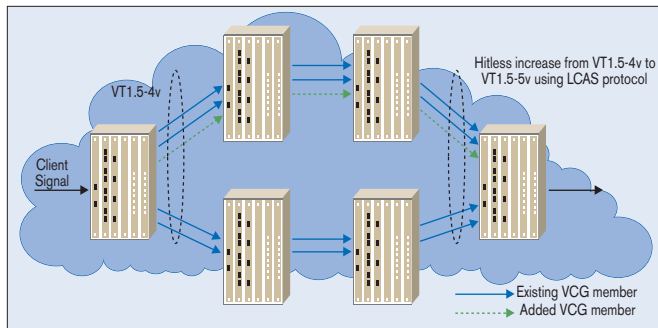

Figure 6.1 Increasing VCG Size Using LCAS

LCAS works by ensuring synchronization between the sender (PTE), referred to as the source node, and receiver (PTE), referred to as the sink node, during the increase/decrease of the size of a virtually concatenated circuit, in such a way that it doesn't interfere with the underlying client data service. Should failures occur on an individual member of a group, the size of the group can be reduced temporarily, instead of taking the entire group out of service (which would be the case if LCAS were not enabled – the entire VCG would be declared as “failed” in the event of a failure of one VCG members). With LCAS, once the defect is repaired, the group size can be restored to full bandwidth without affecting the underlying service.

In addition to providing a resiliency mechanism for VCAT, LCAS gives service providers the flexibility to tailor service bandwidth as required. For example, if a certain customer requires additional bandwidth in the late evenings for file transfers (i.e., banking institutions), the service provider can provide a value-added service by provisioning increased bandwidth for a predefined period. Therefore, by dynamically altering the bandwidth of SONET/SDH transport pipes, LCAS allows network designers to adjust bandwidth based on quality of service (QoS) or other priority considerations.

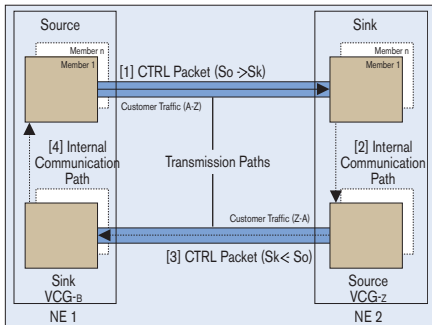

Figure 6.2 LCAS Protocol Transmission

As with VCAT, LCAS is only required at the terminating points of a circuit and the remainder of the network is oblivious to its presence. In order for LCAS to operate, two transmission paths in opposite directions must be established in order to terminate the protocol (see Figure 6.2).

Each of these transmission paths link the network elements (NE) located at each end of the circuit. In the LCAS protocol, one NE is designated as the Source and one is designated as the Sink. This defines an origination path. Another source/sink pair, in the opposite direction, must also be created to serve as a return path. Between two NEs, the LCAS information exchange always proceeds from the Source (So) to the Sink (Sk). The information is packaged in a control packet (CTRL) that contains data about the source members, as well as transferred information from the sink.

Figure 6.2 represents a NE1 source that sends a CTRL packet [1] to the NE2 sink. The NE2 sink receives the CTRL packet and processes it. In addition to the result of this processing, the detected status of its own members is shared with the NE2 source via an internal communication path [2]. At this point, using the return path, the NE2 source sends its own CTRL packet [3], which contains its own CTRL information as well as the NE2 sink information. The LCAS protocol loop is closed when the NE1 sink shares the information that is received from the NE2 sink to the NE1 source via the internal communication path [4]. This information transfer is also done in the same manner if the described scenario originates from the NE2 Source.

6.1 LCAS Control Packets

Below is the list of ITU-defined control packets for both directions of an LCAS signaling link.

Table 6.1 – ITU-Defined LCAS Control Packets

FIXED	Indicates that this end uses fixed bandwidth (non-LCAS mode).
ADD	Indicates that this member is about to be added to the group.
NORM	Indicates that there is no change; steady state.
IDLE	Indicates that this member is not part of the group or about to be removed.
EOS	Indicates the end of sequence; normal transmission.
DNU	Means <i>do not use</i> payload; indicates that the Sk side reported FAIL status.

Table 6.2 – Sink to Source: Depicted as Message [3] in Figure 6.2.

MST	Information from Sk to So about the status of all members of the same VCG. It reports the member status from Sk to So with two states: OK or FAIL (1 status bit per member). OK = 0, FAIL = 1. Since each control packet contains only a limited number of bits for communicating the MST field, this information is spread across multiple control packets; i.e., an MST multiframe.
RS-Ack	When a renumbering of the sequence numbers of the members sending in CTRL field NORM, DNU, EOS, or when a change of the number of these members is detected at the Sk, a notification to the So per VCG has to be performed by toggling (i.e., change from 0 to 1 or from 1 to 0) the RS-Ack bit.

Table 6.3 – Common LCAS Messages for Path [1] and [3].

Both (Common)	
CRC-8	To simplify the variation of the changes in the virtual concatenation overhead, a CRC is used to protect each control packet. The CRC check is performed on every control packet after it has been received, and the content is rejected if the test fails. If the control packet passes the CRC test, then its content is used immediately.

6.2 LCAS Example 1: Capacity Increase

The bandwidth of a VCG can be increased through the LCAS' ability to enable in-service addition of one or more members in a VCG. This bandwidth increase is typically controlled by the user via a network management system. The steps detailed in Figure 6.3 are used to perform this bandwidth increase.

LCAS Bandwidth Increase, OC-12/STM-4 example

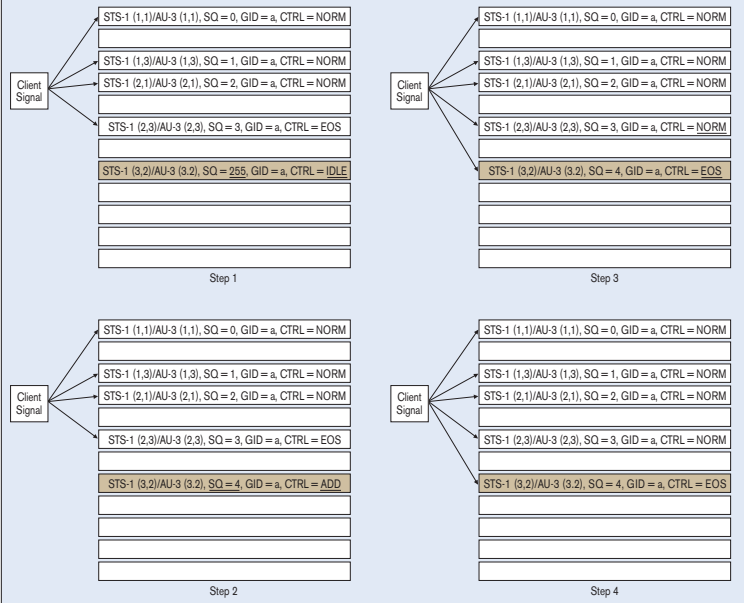

Figure 6.3 Bandwidth Increase

- Step 0: A member needs to be added to an existing VCG that is LCAS-enabled. In this example, the member to add is STS-1[3,2], or AU-3[3,2].
- Step 1: The management system is used to configure the member at the source and sink NE.
 - The source automatically sets the SQ to 255, the highest possible number at the source and the sink NE. (based on VCAT standard)
 - The sink sets the MST to FAIL.
- Step 2: The management system configures LCAS state machine to ADD.
 - In the source, the SQ is automatically set to 4, the next highest SQ available, and the CTRL is set to ADD.
 - The source waits for the sink to send MST = OK for the member with SQ = 4. While waiting for this MST = OK message, the source will continue to send a CTRL = ADD for this member.
- Step 3: The source receives MST = OK for member SQ = 4.
 - The source sends EOS to the last member added, indicating to the sink that this is indeed the last member of the VCG, and sends NORM for the previously defined last member (of course, this is assuming that no fault occurs on this member during that time).
 - The new member begins to carry traffic in the first frame after the last byte in the frame transporting CTRL = NORM/EOS change.

Note: If multiple members were added, all members would be set to NORM, except for the last one in the sequence, which would be set to EOS.
- Step 4: The sink detects the transition from ADD to NORM/EOS for the new member
 - The sink sends RS-ACK to the source to acknowledge the new sequence.
 - The sink sets the MST to be consistent with the new sequence.
 - Following the proper delay compensation, the source is allowed to evaluate the new member status when it receives the RS-Ack.

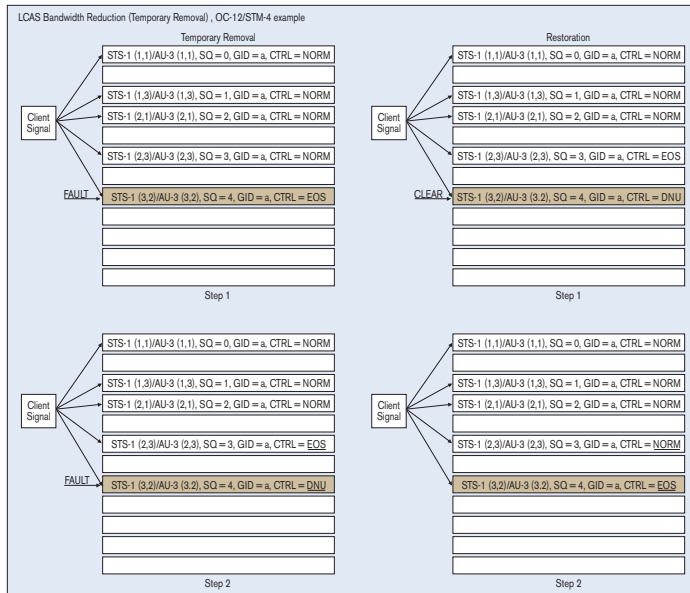

Figure 6.4 Bandwidth Reduction (Temporary Removal)

6.3 LCAS Example 2: Capacity Reduction

There are two methods for LCAS to support the capacity reduction of a VCG: automatic temporary removal of one or more member(s) due to a network fault, or manual deprovisioning of one or more member(s) to permanently reduce the bandwidth supported by the VCG.

Automatic Temporary Removal

The temporary removal of a member is automatically handled by the LCAS protocol, as presented in Figure 6.4 and associated steps. This capability provides VCAT with its resiliency mechanism as the size of the group can be reduced temporarily, instead of taking the entire group out of service (which would be the case for VCGs without LCAS enabled). Once the defect is repaired, the group size can be restored to full bandwidth without affecting the underlying service.

Temporary Removal

- Step 1: A fault is detected at the sink for a member (i.e., STS-1 [3,2], AU-3 [3,2]).
 - At the sink, the fault can take the form of a member status unavailable (MSU) or transport signal degraded (TSD). An MSU would be generated by an AIS or LOP for example. The TSD would be errors detected on the path crossing a certain threshold.
 - If the source of these members was sending a NORM or EOS in this condition, the sink would start sending a MST = FAIL for the specific SQ.
 - Typically, a hold-off timer can be configured to delay the reporting of MST = FAIL to avoid transient error occurrences.
- Step 2: Member removal
 - At the sink NE and upon the detection of the MSU, the member would be removed immediately. However, if the failure is related to a TSD, the member would be removed only when the sink NE receives the DNU from the source NE.
 - At the originating source NE a detection of the MST = FAIL will trigger the replacement of the NORM/EOS by a DNU condition. Within the remaining active member, the member with the highest SQ will send EOS in the CTRL field.

Restoration

- Step 1: Fault clears
 - When the defect that caused the temporary removal is terminated and is detected at the sink, the sink will start sending a MST = OK for that member.
 - Upon detection of the MST = OK, the source will either replace the DNU condition by an NORM condition, or replace the DNU condition with an EOS condition, and the preceding member, which was sending CTRL code EOS, will send NORM in the CTRL field.
- Step 2: Payload activation
 - The final step after recovering from a temporary removal is to start using the payload area of that member again. The first container frame to contain payload data for the member is the container frame immediately following the container frame that contained the last bit(s) of the control packet containing the first CTRL code (NORM or EOS) in the CTRL field for that member.

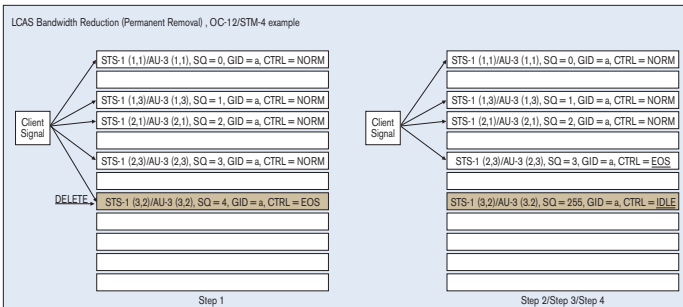

Figure 6.5 Bandwidth Reduction (Permanent Removal)

Member Permanent Removal

The bandwidth of a VCG can be permanently reduced using the LCAS' ability to enable in-service removal of one or more member(s) from the VCG. This bandwidth reduction is controlled by the user via a network management system. The steps detailed in Figure 6.5 are used to perform this reduction of bandwidth.

Note: The removal of a member must be done at the source in order for the operation to be hitless. If it is done at the sink first, the traffic will be corrupted from the time the member is removed (sink generates MST = FAIL) and the sink receives a DNU generated from the source.

- Step 1: One or more member(s) need to be removed from an existing VCG. In this example, again we are using STS-1 [3,2], AU-3 [3,2].
 - This operation must be initiated from a management system.
- Step 2: At the source, the management system deletes the member from the VCG.
 - The CTRL field is set to IDLE, while the SQ is automatically set to 255.
 - Depending on which member is deleted in the VCG, the SQ for the remaining members may be renumbered. For example, if the member that is removed is the highest number in the VCG, the members' SQs will not be renumbered. However, if a member other than the last is removed, then SQ renumbering will occur in line with the new order.
 - The source will send a new CTRL word (changed from NORM to EOS) for the last member of the VCG.
- Step 3: At the sink, the CTRL word and SQ are received.
 - When the CTRL = IDLE signal is detected, the MST for the member is set to FAIL and the RS-Ack is toggled.
- Step 4: At the sink, the management system deletes the member from the VCG.

7

Next-Generation SONET/SDH: Testing Implications

7. Next-Generation SONET/SDH: Testing Implications

With these new technologies comes a new terminology for next-generation SONET/SDH-capable add-drop multiplexers (ADMs). ADMs supporting GFP, VCAT, and LCAS are known in the industry as multiservice provisioning platforms (MSPPs). By deploying MSPPs in their network, a service provider can now deliver packet-based transport services using their existing SONET/SDH infrastructure. As mentioned in Chapters 4, 5 and 6, the intelligence needed to support GFP, VCAT, and LCAS is located at the endpoints of the network; therefore, MSPPs need only be deployed at the edge of the transport network, where services are created.

MSPPs offer obvious advantages to service providers as they help maximize the usage of the current install base with minimal capital expenditure while providing a new revenue stream to fuel growth for the coming years. However, with these new technologies come new deployment challenges. GFP, VCAT and LCAS add another layer of complexity to accommodate the transport of different data services. In many cases, these next-generation functionalities are delivered as enhancements to existing SONET/SDH ADMs. Nevertheless, for a service provider, whether it is delivered by new network elements or enhancements to existing ADMs, this additional layer needs to be fully tested.

In this section, we will briefly discuss testing scenarios that must be considered for next-generation SONET/SDH networking to determine the proper operation of these MSPPs and, consequently, the proper operation of the next-generation data services being offered.

7.1 GFP Test Scenarios

— Conformance Testing

The purpose of these tests is to verify MSPP conformance to GFP ITU-T G.7041 specifications. As we have seen, GFP is responsible for mapping a wide range of clients (Ethernet, ESCON, FICON, etc.) onto the transport layer. Because of this, the GFP frame must have formats and contents that match the payload type. Therefore, next-generation test equipment is used for the following purposes:

- Determine GFP mapping and demapping compliance to G.7041. This is validated by performing end-to-end client signal tests (i.e., Ethernet-over-SONET/SDH circuit continuity). This test should be performed for all required service offerings and rates.
- Validate that GFP is supported over all supported contiguous concatenation paths (i.e., STS-1, STS-3c, STS-12c, STS-48c) and VCAT containers.
- Validate support for extension headers based on required service offering (i.e., null, linear).
- Validate support for the presence and absence of the optional GFP Payload FCS field.

■ Defect Detection and Recovery

The purpose of these tests is to verify the MSPPs' errors and/or alarm detections and recovery mechanisms. During injection of any defects, one must verify that all non-service-affecting defects (i.e., correctable HEC errors) have no adverse effects on the client signal, allowing the network to recover smoothly. In addition, all service-affecting defects, when no longer present, are cleared by the network element and service restored to full operation. Examples:

- GFP error injection and analysis (cHEC/tHEC/eHEC correctable/uncorrectable, pFCS)
- GFP alarm injection and analysis (loss of client signal (LOCS), loss of client character synchronization (LOCCS))
- GFP payload error injection (i.e., injection of Ethernet alarms and errors to verify that no adverse effect on GFP and SONET/SDH layers has occurred)
- GFP overhead manipulation/corruption

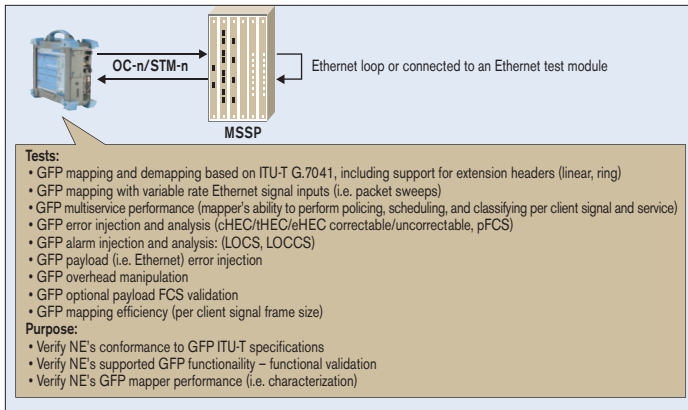

Figure 7.1 GFP Test Scenarios

- Verify the GFP mapping efficiency per client signal frame size; i.e., Ethernet packet sweep from minimum to maximum supported size (jumbo frame) of the client signal.
- GFP multiservice performance. For example, many GFP mapper interface cards support quality-of-service functions such as the ability to perform policing, scheduling, and classifying per client signal and service. Test equipment can be used to emulate this multiservice environment using multiple stream (i.e., Ethernet) each with their own transmission rate and QoS settings (i.e., IP Tos, IP DiffServ, Ethernet 802.1q priority tagging).

Performance Characterization

The purpose of these tests is to verify the MSPPs' GFP mapping and demapping performance and efficiency. For example, given the fact that GFP-F frame sizes, and hence mapping functions, are directly related to the client signal frame size, it is important to verify that the network elements present GFP mapper efficiency in the following areas:

- GFP payload pattern generation (use an internal GFP PRBS pattern generator to vary the GFP payload information field from 0 to 65,535 – X octets, where X is the size of the payload header (including the extension header, if present) and the payload FCS field (if present).

7.2 VCAT Test Scenarios

— Conformance Testing

The purpose of conformance testing is to verify that network elements receive and transmit in conformance to VCAT containers defined in ITU-T G.707 specifications.

As we have seen, virtual concatenation is a very efficient way to transmit data services over SONET/SDH networks. We know that several containers are formed into a common payload (the virtual concatenation group or VCG). The tests described below check that setting up, expansion and reduction of a VCG has been accomplished without errors.

- HO VCAT container support (all valid combinations) – typically used for 100BaseT and Gigabit Ethernet
- LO VCAT container support (all valid combinations) – typically used for sub-rate 10/100BaseT, 10BaseT, and 100BaseT Ethernet services
- Validate the maximum number of VCG members supported (for all valid HO and LO container types)

Table 7.1 – Common HO and LO VCAT Container Types

HO PATH		LO PATH	
SONET	SDH	SONET	SDH
STS-1	VC-3	VT1.5	TU-11
STS-3c	VC-4	VT2	TU-12
		VT6	TU-3
			TU-2

■ Defect Detection and Recovery

The purpose of these tests is to verify the network elements' error and/or alarm detection and recovery mechanisms. During injection of any defects, one must verify that defects are properly identified by the network element and, when they are no longer present, that they are cleared by the network element and service restored to full operation:

- VCAT alarm injection and analysis (LOM, OOM1, OOM2, SQM, LOA)
 - single-member alarm injection
 - multiple-member alarm injection
- For HO VCAT, high-order path error insertion and analysis; e.g., REI-P, B3 errors, etc.
 - single-member alarm injection
 - multiple-member alarm injection
- For LO VCAT, low-order path error insertion and analysis; e.g., REI-P, B3 errors, etc.
 - single-member alarm injection
 - multiple-member alarm injection

Note: These tests should be performed for both non-LCAS and LCAS-configured VCGs.

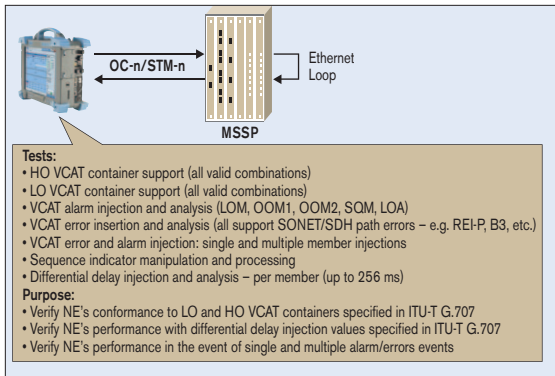

Figure 7.2 VCAT Test Scenarios

Differential Delay Injection and Analysis

As described above, the ITU specification for VCAT states that a differential delay of up to 256 ms must be supported on network elements in order for them to compensate for the delay between arrival times of individual VCG members to their destination (sink mode). However, given the amount of buffering required at the terminating points, it is often the case that next-generation SONET/SDH PTEs support less than this maximum.

The purpose of differential delay injection tests and analyses is to verify the performance of these next-generation network elements against the maximum differential delay that they support. Test equipment must then support both the injection and analysis of differential delay per VCG member (both HO and LO VCAT). The test equipment should support a delay of up to 256 ms, to cover for the maximum, and support a delay injection resolution of at least 125 μ s for HO, and 500 μ s for LO.

7.3 LCAS Test Scenarios

— Conformance Testing

The purpose of LCAS conformance testing is to verify that the MSPPs comply with the LCAS signaling mechanism defined in the ITU-T G.7042 specifications.

As we have seen, LCAS works by ensuring synchronization between the sender PTE (source) and receiver PTE (sink) during the increase/decrease in size of a virtually concatenated circuit, in such a way that it doesn't interfere with the underlying data service. This synchronization ensures that, in the event of VCG member failure, the size of the VCG can be reduced temporarily, instead of taking the entire group out of service (which would be the case if LCAS were not enabled). With LCAS, once the defect is repaired, the group size can be restored to full bandwidth, without affecting the underlying service. In addition to providing a resiliency mechanism for VCAT, LCAS gives users the flexibility to add and remove members to a VCG as needed.

LCAS testing should therefore be focused on ensuring that the following functions are supported on the network element:

- Manual addition and removal of VCG members (tested on all supported HO VCAT containers). Separate tests should be performed for addition and removal of first, last, and middle members. Multiple-member addition and removal should also be performed.
- Manual addition and removal of VCG members (tested on all supported LO VCAT containers). Separate tests should be performed for addition and removal of first, last, and middle members. Multiple-member addition and removal should also be performed.
- Behavior (detection and recovery) in the event of a failure on a VCG member (tested on all supported HO VCAT containers). See the VCAT Defect Detection and Recovery section on page 70 for a list of errors and alarms that should be used.
- Behavior (detection and recovery) in the event of a failure on a VCG member (tested on all supported HO VCAT containers). See the VCAT Defect Detection and Recovery section on page 70 for a list of errors and alarms that should be used.

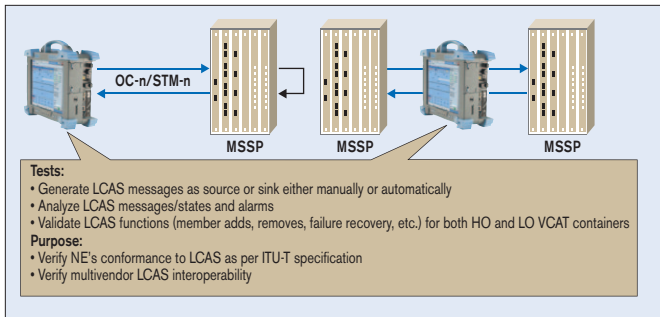

Figure 7.3 LCAS Test Scenarios

7.4 Continuity and Performance Testing

Prior to wide-scale deployment in live networks, next-generation services to be offered (10BaseT, 100BaseT, 1000BaseT, GigE, etc.) must be emulated and tested. In addition, given the fact that multivendor networks are now commonplace and that these technologies are still in their early stages, it is important that proper vendor interoperability tests are performed so as to mitigate risks prior to deployment.

The purpose of these tests is to verify the continuity and performance for all offered services. This is done by creating a test environment that closely matches live network topology and by using a next-generation test unit that supports both client signal interfaces and GFP, VCAT, and LCAS technologies. Continuity between source and sink nodes must be checked, in addition to verifying the maximum number of client signals that can be supported in this configuration, to ensure scalability of the network elements prior to wide-scale deployments.

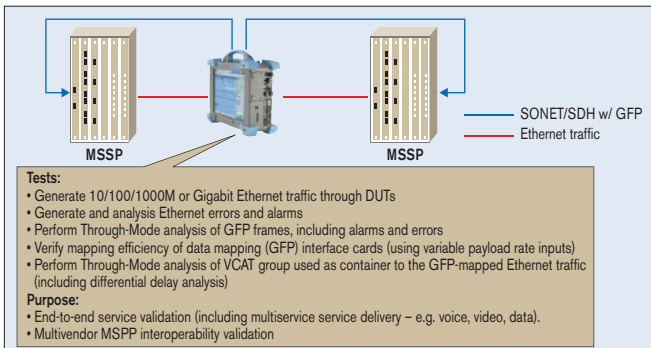

Figure 7.4 Next-Generation Service Continuity and Performance Testing

7.5 Service Turn-Up Testing

With next-generation networks, field technicians must be equipped with versatile test equipment that can provide the necessary functions to turn up both TDM circuits and next-generation packet-based services such as Ethernet and Fibre Channel. Service providers and equipment vendors cannot afford to supply each field technician with a multitude of disparate test equipment to perform their daily duties. Their test units must be capable of supporting legacy TDM (electrical and optical) and next-generation packet-based circuit turn-ups, as well as common client signal test interfaces such as 10/100/1000M Ethernet and Fibre Channel.

Before going into a detailed description of the tests required to qualify TDM and next-generation circuits, it is important to understand that proper testing of any network – whether SONET or Ethernet, fiber or copper – should start from the bottom; that is, at the physical-layer level.

A comprehensive suite of physical-layer tests should be completed prior to any testing in the digital domain. Although we will not be addressing these tests herein, it is essential to know what they are:

- Power loss
- Return loss
- Dispersion (for high-speed optical systems)
- Media profile (splice loss, attenuation, reflectance, etc)

Correctly performing these tests will ensure that future testing is not hindered by any problems in the underlying physical media, preventing the waste of valuable turn-up time to search for hidden glitches.

For guidance on these and other physical-layer testing applications, please refer to EXFO's website at www.EXFO.com, or contact your local representative.

As with any circuit turn-up, typical tests involve performing a bit-error-rate testing for the end-to-end connection, whether the circuit is TDM or packet-based.

The bit-error-rate (BER) test provides a complete qualification of the payload-carrying ability of the SONET/SDH circuit. As this is always an out-of-service type test, it is vital that a complete BER test be passed prior to user traffic being commissioned onto the system. Below is a simple, generalized view of this procedure:

1. Connect the test unit to the next-generation PTE of the appropriate client interface (Ethernet, FC, TDM).
2. Set up the test unit with the appropriate test configuration (i.e., Ethernet, FC, DSn/PDH, SONET/SDH) and desired BERT pattern.
3. Make sure the test unit reports no alarms or errors.
4. Let the test run for a pre-determined amount of time. The duration of the test can vary, as service turn-up requirements differ per service provider. A typical duration is 24 hours.
5. During and at the end of the test, consult the logger, preferably saving the results for post-test analysis.

Note:

- *Alternatively to the BERT test, for Ethernet over SONET/SDH circuits, an RFC 2544 test is also recommended.*
- *For VCAT-configured next-generation circuits, VCAT differential delay analysis at the sink node would be required to ensure that the viewed differential delay for that VCG is well below the network elements stated maximum supported delay. This will help ensure that, over time, service degradation issues are not encountered over time. Please see diagram below for details.*

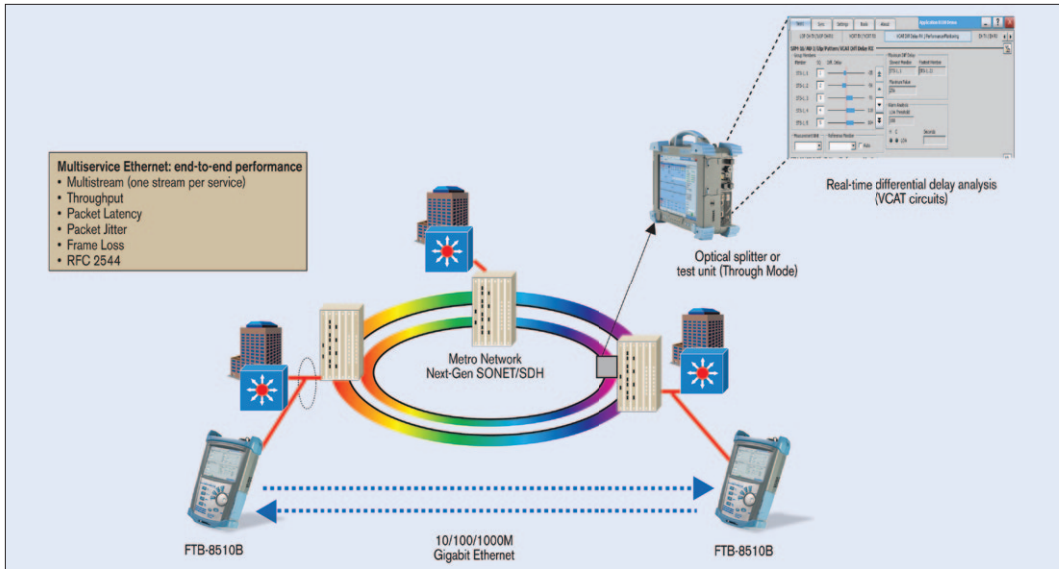

Figure 7.5 Next-Generation Service Turn-Up

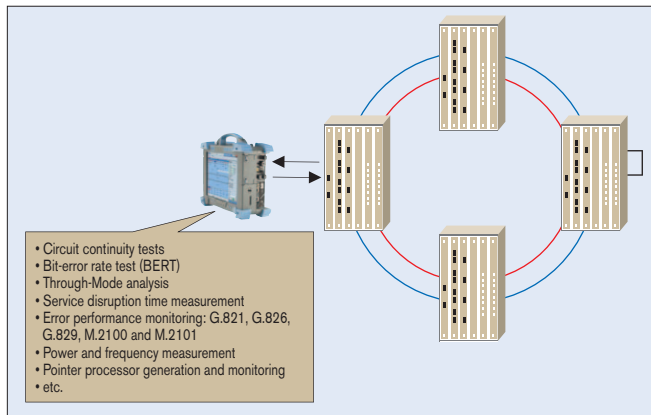

Figure 7.6 TDM Circuit Turn-Up and Troubleshooting

7.6 Network Troubleshooting

Once next-generation services are deployed, service providers are left with the challenge of ensuring that their end-to-end data services perform according to signed service-level agreements. Post-deployment troubleshooting and maintenance activities must not only include legacy SONET/SDH-layer visibility, but also visibility at the higher GFP, VCAT and LCAS layers.

Service providers require a test solution that can identify and correlate any potential problems that can normally occur throughout the network but, more importantly, across multiple layers; namely, the physical, SONET/SDH, GFP, VCAT and data (Ethernet, Fibre Channel) layers. Why? Well, let us consider the following example. Dribbling errors encountered on a point-to-point Ethernet-over-SONET/SDH circuit could be an issue with the client

signal mapping function of the PTE equipment. This problem with the mapper could be a result of a degradation of the unit over time, or due to loading factors not experienced until recently (i.e., developed as more client traffic flows through the network). Or, conversely, issues could have resulted through configuration errors of the VCG, or signaling errors with the LCAS protocol.

Regardless of the issue, service-provider field technicians must be equipped with the proper tools to diagnose network problems, ensuring that downtime is kept to a minimum.

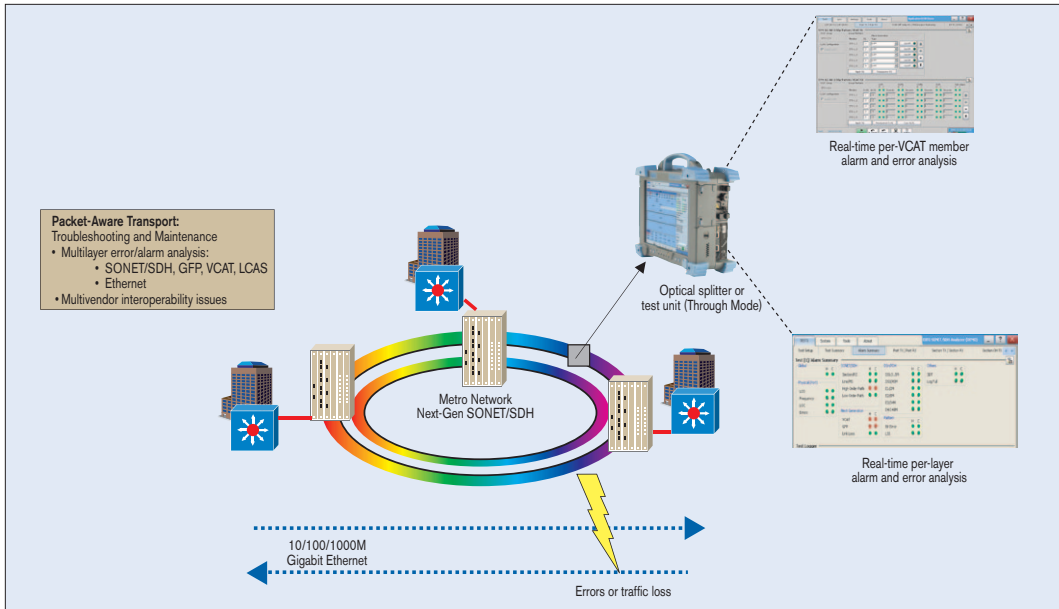

Figure 7.7 Ethernet-over-SONET/SDH Troubleshooting and Maintenance

8

Conclusion



8. Conclusion

Next-generation SONET/SDH deployment has come of age and has gained significant acceptance in metro network applications. More than half of SONET/SDH network elements sold to date supported data-aware next-generation enhancements, including generic framing procedure (GFP), virtual concatenation (VCAT) and, in some cases, link-capacity adjustment scheme (LCAS).

Metro SONET/SDH now accounts for over 75% of SONET/SDH CAPEX spending by service providers, a substantial shift from 2000, when long-haul installations accounted for half of all elements purchased (sources: Dell'Oro).

There is solid logic behind this shift towards next-generation SONET/SDH. As Ethernet now dominates as the leading data transmission standard, less efficient packet-over-SONET schemes are being migrated to the more versatile and flexible next-generation standards described in this document. With service demand and, consequently, service-provider revenue growth shifting from these legacy TDM-based services to Ethernet-based services, next-generation SONET/SDH technologies offer the robustness, flexibility, and versatility to fulfill this growing market demand.

9

Next-Generation Alarms Index

9. VCAT Alarms

High-Order (HO VCAT):

- OOM1 (out-of-multiframe of stage 1): The OOM1 is declared when an error is detected in the MFI1 sequence. The OOM1 state is cleared when error-free MFI1 sequences are found in four consecutive STS-1/STS-3c or VC-3/VC-4 frames; then, an IM1 state is declared.
- OOM2 (out-of-multiframe of stage 2): The OOM2 is declared when an error is detected in the MFI2 sequence or when the first multiframe stage is in the OOM1 state. The OOM2 state is cleared when IM1 state is declared, while error-free MFI2 sequences are found in two consecutive first-stage multiframe; then, an IM2 state is declared.
- LOM (loss of multiframe): The LOM alarm is declared when an OOM1 or OOM2 is present while the whole H4 is not recovered within 40 to 80 STS-1/STS-3c or VC-3/VC-4 frames. The LOM state is cleared when both multiframe alignment processes are in the in-multiframe states IM1 (Stage 1) and IM2 (Stage 2).
- SQM (sequence indicator mismatch): An SQM is declared when the accepted sequence indicator (AcSQ) does not match the expected sequence indicator (ExSQ). The SQM state is cleared when the AcSQ matches the ExSQ.
- LOA (loss of alignment): An LOA defect is generated when the delay calculation process cannot perform the alignment of the considered members to a common multiframe start for any reason (e.g., LOA is detected if the differential delay exceeds the size of the alignment buffer). The LOA can also be declared if it crosses a user configurable threshold.

Low-Order (LO VCAT):

- OOM1 (out-of-multiframe of stage 1): The OOM1 is declared when two consecutive frame alignment sequence (FAS) are detected in error. This condition is cleared when one non-errored FAS is found.
- OOM2 (out-of-multiframe of stage 2): The OOM2 is declared when the OOM1 is reached or when an error is encountered in the received and expected frame count from bits 1-5 of the Z7(2)/K4(2) sequence. This condition is cleared when two consecutive error-free frame members are recovered.
- LOM (loss of multiframe): The LOM alarm is declared when any of the two multiframe alignment processes is in the out-of-multiframe (OOM1 or OOM2) state and the whole K4 (bit 1 and 2) two-stage multiframe is not recovered within 200 to 400 VC-11/12 or VT1.5/2 frames. This condition is cleared when both alignment processes are in-multiframe state IM1 (Stage 1) and IM2 (Stage 2).
- SQM (sequence indicator mismatch): An SQM is declared when the accepted sequence indicator (AcSQ) does not match the expected sequence indicator (ExSQ). The SQM state is cleared when the AcSQ matches the ExSQ.

- **LOA (loss of alignment):** An LOA defect is generated when the delay calculation process cannot perform the alignment of the considered members to a common multiframe start for any reason (e.g., LOA is detected if the differential delay exceeds the size of the alignment buffer). The LOA can also be declared if it crosses a user configurable threshold.

LCAS Alarms:

Source

- **Partial Loss of Capacity Transmission (PLCT):** The PLCT alarm is declared when the PLCT threshold (PLCTThr) is reached under the conditions that the number of active members is $XAT > 0$ and the number of provisioned members is $XPT > 0$. The threshold is defined as one or more member(s) in DNU (Do Not Use) state. The PLCT alarm is cleared when the number of members in $DNU < PLCTThr$.

Note:

XAT or XAR = Members that are in a NORM or EOS state (transporting traffic) in the transmit or receive directions.

XPT or XPR = Members that are in NORM or DNU state (members that were successfully added in the VCG) in the transmit or receive directions.

- **Total Loss of Capacity Transmission (TLCT):** The TLCT alarm is declared when the number of active members is $XAT = 0$ and the number of provisioned members is $XPT > 0$. The TLCT alarm is cleared when the $XAT > 0$.
- **Failure of Protocol Transmission (FOPT):** The FOPT alarm is declared when UMST (Unexpected Member Status) is present. The FOPT alarm is cleared when no UMST is present.
- **Unexpected Member Status (UMST):** The UMST alarm is declared when $MST = OK$ for a member that does not carry the CTRL word ADD, NORM, EOS, or DNU.

Sink

- **Inconsistent SQ (SQNC):** The SQNC alarm is declared when the members that carry the "NORM", "DNU" or "EOS" message do not have a unique sequence indicator. The SQNC is cleared when the "NORM", "DNU" or "EOS" message has a unique SQ in the VCG.
- **Partial Loss of Capacity Receive (PLCR):** The PLCR alarm is declared when the PLCR threshold (PLCRThr) is reached under the conditions that the number of active members is $XAR > 0$ and the number of provisioned members is $XPR > 0$. The threshold is defined as one or more member(s) in FAIL state. The PLCR alarm is cleared when the number of members in $MST\ GEN = FAIL < PLCRThr$.
- **Total Loss of Capacity Receive (TLCR):** The TLCR alarm is declared when the number of active members is $XAR = 0$ and the number of provisioned members is $XPR > 0$. The TLCR alarm is cleared when the $XAR > 0$.
- **Failure of Protocol Receive (FOPR):** The FOPR alarm is declared when CRC or SQNC is present. The FOPR alarm is cleared when no CRC error or SQNC is present for the member(s).

- Persistent CRC (CRC): A Persistent CRC defect is generated when there is a high number of CRC-3 or CRC-8 errors on consecutive control packets on LOP as well as HOP respectively, provided both CRC and CTRL word are unequal to 0 and no Member Signal Unavailable (MSU) alarm exist.
- Inconsistent SQ (SQNC): The SQNC alarm is declared when the members that carry the "NORM", "DNU" or "EOS" message do not have a unique sequence indicator. The SQNC is cleared when the "NORM", "DNU" or "EOS" message has unique SQ in the VCG.

GFP Alarms/Defects:

- LFD (loss-of-frame delineation): The LFD alarm is declared for any cHEC uncorrectable error (multiple-bit error).
- LOCS (loss-of-client signal): The LOCS alarm is detected when the loss-of-client-signal event occurs.
- User-Defined CMF (client management frame): Refer to the user-defined UPI field information in the GFP section of this document. Currently, the LOCCS (Loss-of-Client Character Synchronization) has been defined as a CMF related alarm.
- cHEc Correctable: Indicates that only one bit error has been detected in the cHEC (PLI field).
- cHEc Uncorrectable: Indicates that two or more bit errors have been detected in the cHEC (PLI Field).
- eHEC Correctable.: Indicates that only one bit error has been detected in the eHEC (CID and Spare Fields). Only available with linear frames (i.e., EXI is set to Linear).
- eHEC Uncorrectable: Indicates that two or more bit errors have been detected in the eHEC (CID and Spare fields). Only available with linear frames (EXI is set to Linear).
- tHEC Correctable: Indicates that only one bit error has been detected in the tHEC (PTI, PFI, EXI and UPI fields).
- tHEC Uncorrectable: Indicates that two or more bit errors have been detected in the tHEC (PTI, PFI, EXI and UPI fields).
- pFCS: Indicates that only one bit error has been detected in the pFCS. Only available when Client Data Frames FCS is enabled.

10

Acronyms Index

10. Acronyms Index

ADM: Add/Drop Multiplexer

AIS-L: Line Alarm Indication Signal

AIS-P: Path Alarm Indication Signal

APS: Automatic Protection Switching

AU: Administrative Unit

AUG: Administrative Unit Group

BER: Bit Error Rate

BERT: Bit-Error-Rate Test

CDF: Client Data Frame

cHEC: Core Header Error Check

CMF: Client Management Frame

CMF: Client Management Frames

DCC: Data Communications Channel

eHEC: Extension Header Error Check

EXI: Extension Header Identifier

GbE: Gigabit Ethernet

GFP: Generic Framing Procedure

GFP-F: Frame-Mapped

GFP-T: Transparent-Mapped

HO TCM: Higher-Order Tandem Connection Monitoring

HO VCAT: High-Order Virtual Concatenation

LCAS: Link-Capacity Adjustment Scheme

LFD: Loss-of-Frame Delineation

LOCS: Loss-of-Client Signal

LOH: Line Overhead

LOM: Loss of Multiframe

LO VCAT: Low-Order Virtual Concatenation

LTE: Line-Terminating Equipment

MAPOS: Frame-Mapped Multiple Access Protocol over SDH

MFI: Multiframe Indicator

ML-PPP: Multilink PPP

MS: Multiplex Section

MSPP: Multiservice Provisioning Platform

NE: Network Element

OAM&P: Operations, Administration, Maintenance, and Provisioning

OC: Optical Carrier

OOM1: Out-of-Multiframe (stage 1)

OOM2: Out-of-Multiframe (stage 2)

PDU: Packet Data Unit

pFCS: Payload FCS

PFI: Payload FCS Indicator

PLI: Payload Length Indicator

PM: Performance Monitoring

POH: Path Overhead

PoS: Packet-over-SONET

PPP: Point-to-Point Protocol

PTE: Path-Terminating Equipment

PTI: Payload Type Identifier

RDI: Remote Defect Indication

RDI-P: Path Remote Defect Indication

REI-L: Line Remote Error Indication

RS: Regenerator Section

SDH: Synchronous Digital Hierarchy

SONET: Synchronous Optical NETWORKing

SPE: Synchronous Payload Envelope

SQ: Sequence Number

SQM: Sequence Indicator Mismatch

SSMB: Synchronization Status Message Byte

STE: Section terminating equipment

STM: Synchronous Transport Module

tHEC: Type Header Error Check

TOH: Transport Overhead

TU: Tributary Unit

TUG: Tributary Unit Group

UPI: User Payload Identifier

VC: Virtual Container

VCAT: Virtual Concatenation

VT: Virtual Tributary

11

References



11. References

- Next Generation SONET/SDH, Stamatios V. Kartalopoulos (ISBN 0-471-61530-7)
- Next Generation SONET/SDH Networks White Paper, Intel
- Virtual concatenation tutorial: enhancing SONET/SDH networks for data transport, Larry Choy, Cisco Systems
- Towards carrier-class Ethernet based access and metropolitan area networks, Maurice GAGNAIR, Ecole Nationale Supérieure des Télécommunications
- Demystifying Ethernet Over SONET (EOS), Gurdip Jande Larscom
- Multidrop Generic Framing Procedure (GFP-MD), Kari Seppanen, Technical Research Centre of Finland (VTT), Information Technology Research Institute
- Generic Framing Procedure (GFP): The Catalyst for Efficient Data over Transport, Paul Bonenfant and Antonio Rodriguez-Moral, Photuris, Inc.
- The Generic Framing Procedure (GFP): An Overview, Enrique Hernandez-Valencia, Lucent Technologies Michael Scholten and Zhenyu Zhu, AMCC
- Metropolitan Area Network Offerings Packet Over SONET, ATM, & Gigabit Ethernet, Foundry Networks
- The future in the metro - Next-generation SDH or plain Ethernet?, Sami Lallukka, Riikka Lemminkäinen
- Next Generation Networks and the Cisco Carrier Routing System, Cisco Systems
- IEEE 802.17 Resilient Packet Ring Working Group (RPR WG), Mike Takefman
- Ethernet over SONET GFP, VCAT and LCAS, Serge-Paul Carrasco Carrasco & Associates
- SONET, Second Edition, by Walter J. Goralski
- Synchronous Digital Hierarchy (SDH), The International Engineering Consortium
- The Fundamentals of SDH, Telecommunication Techniques Corporation
- The Fundamentals of SONET, Telecommunication Techniques Corporation
- Various ITU, IEEE, RFCs etc.

Acknowledgements

This guide would not have been possible without the valuable input and teamwork of the EXFO team; particularly Mr. Claudio Mazzuca, B.Eng., M.B.A, Senior Product Manager; Ms. Mai Abou-Shaban, B.Eng, Application Engineer; Mr. Robert Gendron, B.Eng, Systems Engineer; and Mr. Luc Germain, B.Eng, Systems/Architecture Manager.

No part of this guide may be reproduced in any form
or by any means without the prior written permission of EXFO.

Printed and bound in Canada

ISBN 1-55342-005-5

Legal Deposit–National Library of Canada 2004

Legal Deposit–National Library of Quebec 2004

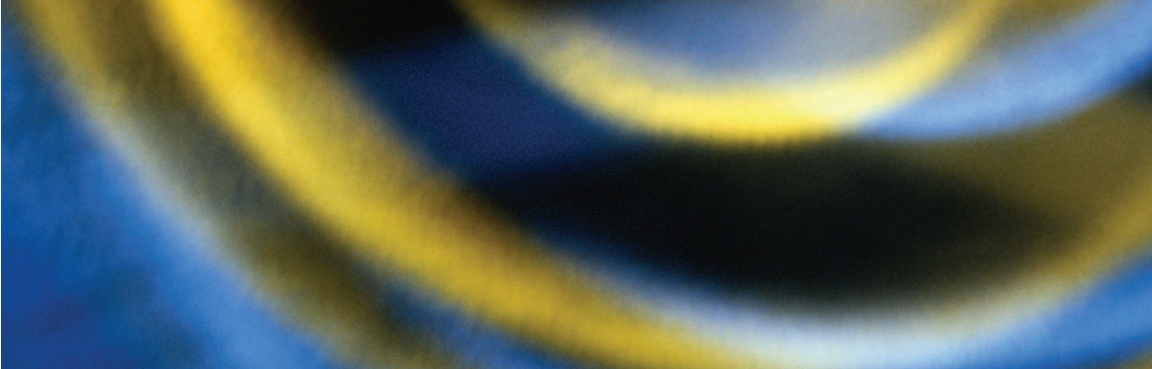

For details on any of our products and services, or to download technical and application notes, visit our website at www.EXFO.com.