

# CTP10

## COMPONENT TEST PLATFORM

- Efficiently test passive optical components in 24/7 operations. Perform insertion loss (IL), return loss (RL), polarization dependent loss (PDL) and photocurrent measurements across the full telecom wavelength range with unprecedented dynamic range, speed and optical resolution.



### KEY FEATURES AND BENEFITS

Fast, accurate and repeatable swept wavelength measurements of IL, RL, PDL and photocurrent

Unprecedented operational wavelength range and femtometer-scale performance

Full dynamic range IL characterization in a single sweep, ideal for components with high-contrast spectrum

10-slot platform with hot-swappable modules to test components from a few to 100+ outputs with daisy-chaining

Easy test configuration, measurement automation and data analysis

Optical power data logging and analog signal output for use with external optical alignment systems

### RELATED PRODUCTS



T200S  
high-power continuously  
tunable laser



T500S  
high-power continuously  
tunable laser

## CTP10 PLATFORM

The CTP10 is a modular passive optical component testing platform that combines speed, accuracy and flexibility. Based on the swept wavelength technique and operating in conjunction with EXFO's continuously tunable lasers, the CTP10 offers reliable, high-quality IL, RL or PDL measurement regardless of wavelength range or spectral characteristics of the device under test. The platform also allows measurement of photocurrent when connected to external photodiodes. Additional capabilities include optical power logging and analog signal output suited for automated optical alignment processes or for capturing optical transient phenomenon.

Thanks to its innovative approach, the CTP10 also greatly reduces setup time and simplifies spectral characterization by taking care of many complex operations. Indeed, the platform directly controls one or several continuously tunable lasers to achieve high-resolution spectral characterization within seconds. Wavelength sweep, data collection and processing for IL, RL or PDL, trace display and analysis are all performed from a single instrument, making the CTP10 a compelling, easy-to-use test solution for passive component characterization. Single-sweep insertion loss measurements with up to 80 dB dynamic range can be performed with unprecedented speed and resolution. Thanks to its modular configuration, it is the ideal instrument to characterize large port count components used in DWDM networks and photonic integrated circuits (PIC).

The platform runs a dedicated operating system with powerful data processing electronics to virtually eliminate any downtime due to data transfer. It also features a large internal hard drive for direct data storage and full remote control via SCPI-compatible commands.

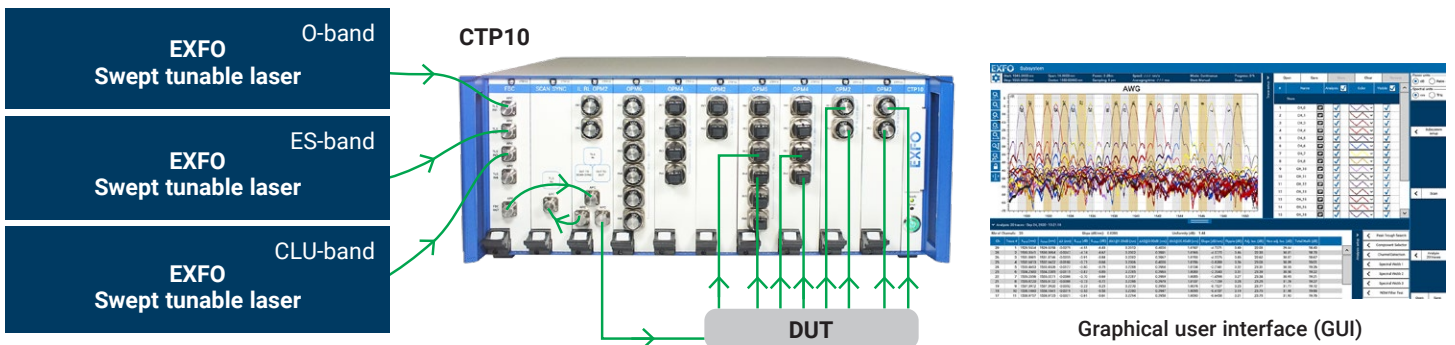

## POWERFUL, INTUITIVE GUI

The feature-rich software offers a powerful and intuitive GUI to easily configure, reference the system and perform measurements. Built-in analysis functions are available to analyze components such as WDM filters or WSS.

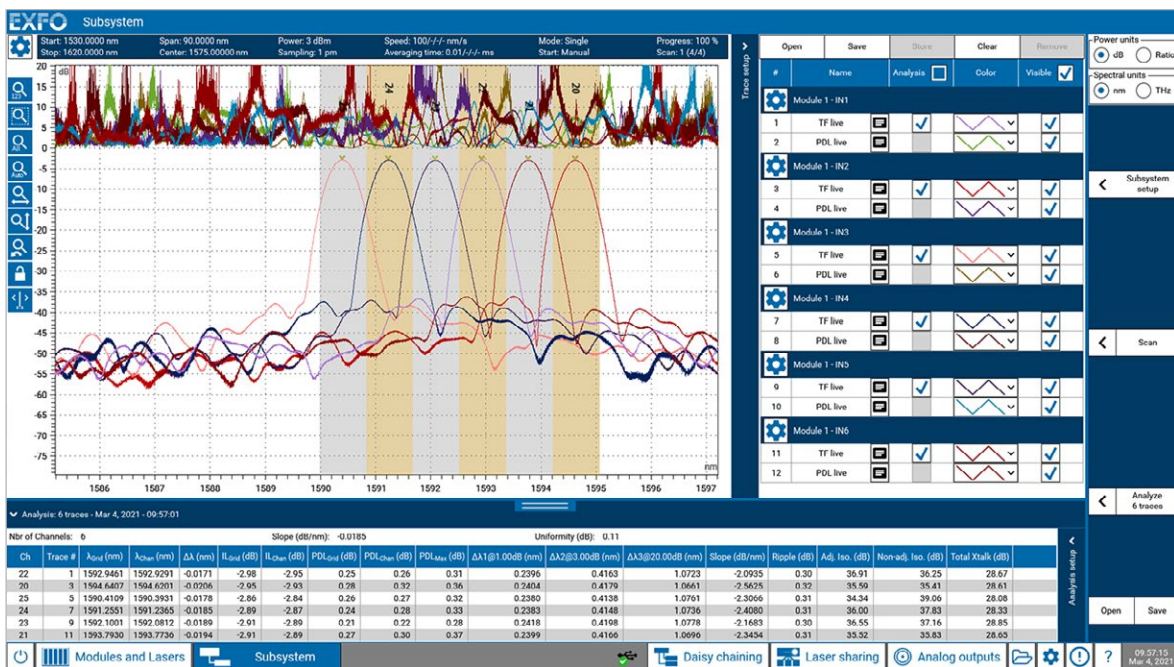

## BEST-IN-CLASS IL, RL AND PDL OVER FULL SPECTRAL RANGE

Fast and reliable IL, RL and PDL measurements are key to any R&D or manufacturing passive component test bench. Other parameters such as isolation, free spectral range or directivity all rely on a high-quality loss measurement.

Thanks to state-of-the-art electronics, the CTP10 offers a dynamic range of 70 dB for IL in a single sweep for a tunable laser speed at 100 nm/s with 10 dBm output power while maintaining a sampling resolution of 1 pm and eliminates post-processing steps such as trace stitching and bandwidth correction. High-resolution measurements down to 20 fm (femtometers) are also possible at scanning speeds of 20 nm/s.

Each functional module is automatically recognized by the CTP10 operating system and unlocks relevant functionalities. For example, when an IL PDL OPM2 module is in use, the CTP10 will automatically generate known states-of-polarization (SOP), record all relevant spectra in each of those states and calculate both PDL and polarization-averaged IL using the Mueller method. The module measures high precision PDL from 1260 nm to 1620 nm. Coupling it with an FBC-M module will automatically enable true full-band IL/PDL characterization.

The CTP10 can test components with a high-contrast spectrum, such as wavelength selective switches or DWDM multiplexers (at a scanning speed of 200 nm/s), without compromising on the quality of optical power measurement. The module's detectors have no slew rate issues and can readily measure a change in insertion loss of more than 10 dB/pm at 100 nm/s scanning speed. Each power meter can also be used in a logging mode or in providing analog signal for automated alignment, critical in optimizing testing time.

## INTEGRATED PHOTONICS CHARACTERIZATION

Photonic integrated circuits are changing many aspects of Test & Measurement, while bringing new characterization challenges—particularly when it comes to spectrum acquisition, often with resolutions of the order of 100 fm or smaller.



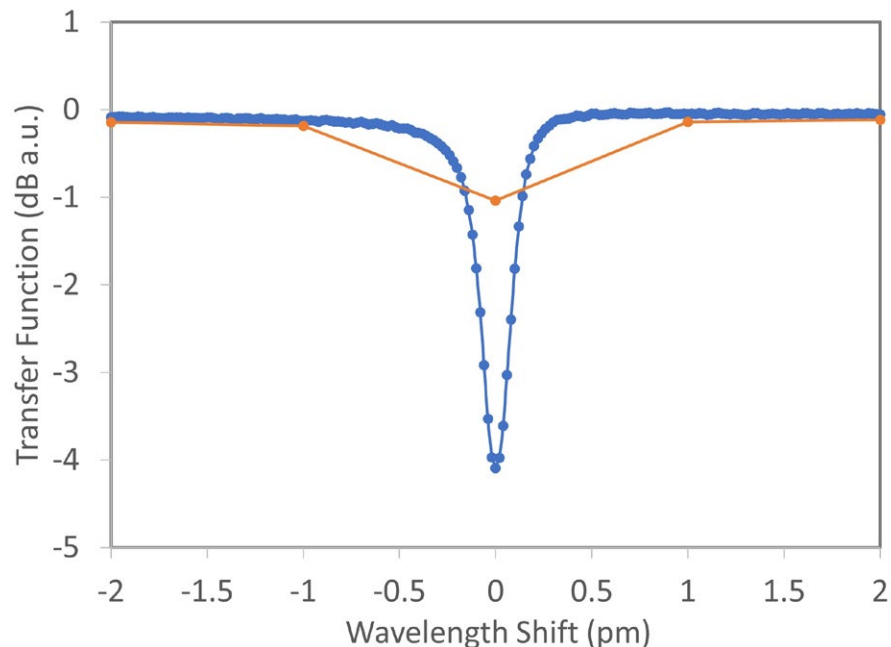



The CTP10 has been developed to meet the industry's dire need for speed and accuracy in terms of high-precision, high-contrast and high-resolution spectral characterization. The modular design provides tremendous flexibility and ease of use—moving the test solution into production, increasing the capacity of a particular setup or adding functionalities.



*Spectral response of a high Q-factor ring resonator using resolutions of 1pm (red) and 20 fm (blue) measured with the CTP10 component testing platform. Device courtesy of CEA-leti.*

## NEXT-GEN MODULES

The CTP10 platform hosts up to 10 hot-swappable modules, providing a variety of optical tools to perform high-quality IL, RL, PDL or photocurrent measurements.

CTP10 MODULES	
KEY MODULES	<div style="display: flex; justify-content: space-between;"> <div style="width: 45%;">  <p><b>Insertion and polarization dependent loss</b></p> <p>Featuring real-time power monitoring and an integrated polarization generator, the <b>IL PDL OPM2</b> performs IL and PDL measurements over 1240 nm - 1680 nm and has two optical detectors. The <b>IL PDL</b> module enables high resolution IL and PDL measurement over the SCL band.</p> <p>2-slot module</p> </div> <div style="width: 45%;">  <p><b>Insertion and return loss</b></p> <p>Featuring real-time power monitoring, return loss measurement and two optical detectors, the <b>IL RL OPM2</b> enables high resolution IL and RL measurement over the full operating wavelength range.</p> <p>1-slot module</p> </div> </div>
WAVELENGTH CONTROL	<div style="display: flex; justify-content: space-between;"> <div style="width: 45%;">  <p><b>Wavelength detection</b></p> <p>Based on high-speed optical triggered wavelength detection, the <b>SCAN SYNC</b> module offers uncompromising wavelength accuracy and sub-picometer sampling resolution even for high-speed testing.</p> <p>1-slot module</p> </div> <div style="width: 45%;">  <p><b>Full-band combiner</b></p> <p>The <b>FBC</b> module offers automated testing across the full telecom range by combining up to 4 tunable lasers into a single output. The <b>FBC-M</b> is a full-band combiner with polarization-maintaining fiber and is required for multi-laser IL-PDL measurement with the IL PDL OPM2 module.</p> <p>1-slot module</p> </div> </div>
DETECTORS	<div style="display: flex; justify-content: space-between;"> <div style="width: 45%;">  <p><b>Optical detectors</b></p> <p>With a choice of 2, 4 or 6 high-speed InGaAs detectors per unit, the <b>OPMx</b> series module feature state-of-the-art electronics to enable full dynamic range measurement in a single laser sweep.</p> <p>1-slot module</p> </div> <div style="width: 45%;"></div> </div>
CURRENT	<div style="display: flex; justify-content: space-between;"> <div style="width: 45%;">  <p><b>Photocurrent meters</b></p> <p>With a choice of 2 or 6 triaxial inputs for photocurrent measurement, <b>PCMx</b> series modules feature single range photocurrent detection along with other CTP10 spectral performances. Triaxial cables as well as photodiodes are offered as accessories for free-space detection applications.</p> <p>1-slot module</p> </div> <div style="width: 45%;"></div> </div>

## PASSIVE OPTICAL COMPONENT TESTING

TYPICAL COMPONENT CHARACTERIZATION SETUP	CTP10 CONFIGURATION					
<p><b>IL and RL</b>                      Typical examples:</p> <ul style="list-style-type: none"> <li>• WDM components</li> <li>• Photonic integrated circuits (PIC)</li> </ul>		 <p>IL RL OPM2</p>	 <p>SCAN SYNC</p>	+	 <p>OPMx</p>	 <p>8x</p>
<p><b>IL and RL, full-band characterization</b>                      Typical examples:</p> <ul style="list-style-type: none"> <li>• PON components</li> <li>• Thin film filters</li> </ul>	 <p>FBC</p>	 <p>IL RL OPM2</p>	 <p>SCAN SYNC</p>	+	 <p>OPMx</p>	 <p>7x</p>
<p><b>IL and PDL, C+L bands characterization</b>                      Typical examples:</p> <ul style="list-style-type: none"> <li>• Wavelength selective switches</li> <li>• DWDM multiplexers</li> </ul>		 <p>IL PDL OPM2</p>	 <p>SCAN SYNC</p>	+	 <p>OPMx</p>	 <p>7x</p>
<p><b>IL and PDL, full-band characterization</b>                      Typical examples:</p> <ul style="list-style-type: none"> <li>• CWDM components</li> <li>• Interferometers</li> <li>• Optical filters</li> </ul>	 <p>FBC-M</p>	 <p>IL PDL OPM2</p>	 <p>SCAN SYNC</p>	+	 <p>OPMx</p>	 <p>5x</p>
<p><b>IL and photocurrent measurements</b>                      Typical examples:</p> <ul style="list-style-type: none"> <li>• PIC with integrated photodiodes</li> <li>• Free-space characterization of thin film filters</li> </ul>		 <p>IL RL OPM2</p>	 <p>SCAN SYNC</p>	+	 <p>OPMx</p>	 <p>PCMx</p>

Our team of experts is available to assist customers in defining the system as per specific optical test requirements.

## HIGH-RESOLUTION SPECTRAL MEASUREMENT

Included as standard in the SCAN SYNC module, the high-resolution scanning mode of the CTP10 provides repeatable and accurate wavelength information well below the picometer, with a minimum sampling resolution of 20 fm at a scanning speed of 20 nm/s. An ideal tool for the spectral characterization of integrated photonics.

## ELECTRICAL ANALOG OUTPUTS

The CTP10 provides two electrical analog outputs that can be configured via software to provide the analog signal detected by any OPM of the system. Leveraging the OPM's detection speed and dynamic range offered for alignment purposes, the CTP10 provides a single-instrument solution for optical beam searching and spectral testing.

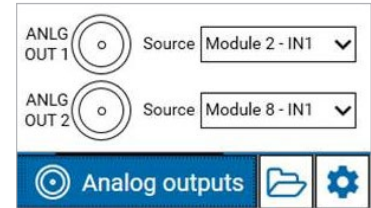

## FULL-BAND READY

The IL RL OPM2 and IL PDL OPM2 modules operate over the 1240 nm - 1680 nm wavelength range and can be used with multiple continuously tunable lasers using the FBC or FBC-M modules. When combining several lasers, the CTP10 automatically switches between lasers for seamless, full-band testing.

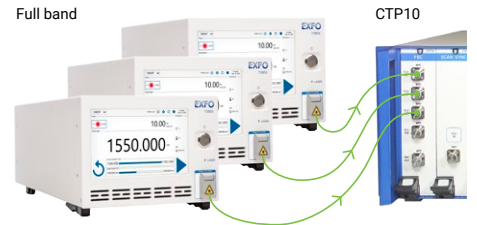

## ADVANCED CONFIGURATIONS

Testing high port-count components is as simple as connecting an additional CTP10 mainframe to an existing system. Available with the IL PDL OPM2 module, the daisy chaining function allows seamless configuration through the GUI to perform both reference and measurement on all detectors from one CTP10.

A trigger-based logging functionality allows use of external trigger sources such as tunable lasers or SMU to perform optical power measurement. Temporal logging can be used in the case of recording transient phenomena.

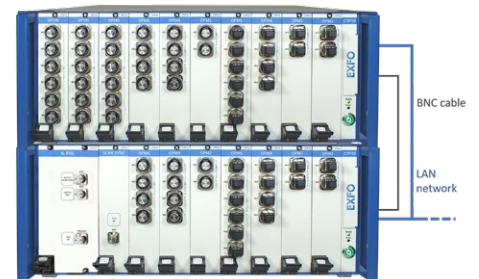

## OPTICAL AND PHOTOCURRENT MEASUREMENTS

While OPMx modules provide optical power measurements used to calculate optical loss through a device under test (DUT), PCMx modules provide a direct reading, in ampere (A), of the photocurrent measured from an external photodiode.

EXFO also supplies—as accessories—a triaxial cable and an InGaAs photodiode compatible with the PCMx modules and with EXFO's Fibre Optic Adaptors (FOA).

## WAVELENGTH REFERENCING GAS CELLS

Packaged external gas cells with NIST traceable absorption lines are available in the O and C bands. This accessory can be used to regularly verify system performance and reference the SCAN SYNC module against the traceable reference material, ensuring excellent absolute wavelength accuracy at all times.

The WLRM-NS270x accessories use a Hydrogen Cyanide (HCN) gas cell in the C band and a Hydrogen Fluoride (HF) gas cell in the O band.



SPECIFICATIONS <sup>a</sup>

SPECTRAL MEASUREMENT				
		With IL PDL	With IL PDL OPM2	With IL RL OPM2
Wavelength	Specified wavelength range	1510 nm–1620 nm	1260 nm–1620 nm	1250 nm–1630 nm
	Operating wavelength range <sup>b</sup>	1440 nm–1640 nm	1240 nm–1680 nm	
	Wavelength uncertainty (typical)	±5 pm		
	Wavelength repeatability (typical) <sup>c</sup>	±1 pm		
	Wavelength display resolution	Standard mode: 1 pm to 250 pm High-resolution mode: 0.02 pm to 0.5 pm		
Optical interfaces	Optical connectors	IN: FC/APC, PM ; OUT: FC/APC, SMF		FC/APC, SMF
	Maximum safe power	TLS IN: 15 dBm SCAN SYNC: 14 dBm		
Insertion loss <sup>d</sup>	Dynamic range (typical at 10 nm/s)	> 80 dB		
	Dynamic range (typical at 100 nm/s)	> 70 dB		
	Noise 2 $\sigma$ (at 10 nm/s) (typical)	0 dB to 20 dB: ±0.005 dB 20 dB to 40 dB: ±0.005 dB 40 dB to 50 dB: ±0.01 dB 50 dB to 60 dB: ±0.035 dB		
	Noise 2 $\sigma$ (at 100 nm/s) (typical)	0 dB to 20 dB: ±0.005 dB 20 dB to 40 dB: ±0.01 dB 40 dB to 50 dB: ±0.05 dB 50 dB to 60 dB: ±0.40 dB		
Polarization dependent loss	PDL measurement method	4-States Mueller		N/A
	PDL uncertainty (typical at 100 nm/s) <sup>e</sup>	±0.06 dB + 2% PDL	±0.06 dB + 1% PDL <sup>f</sup>	N/A
Return loss	Dynamic range (typical at 10 nm/s)	N/A		> 55 dB
	Return loss uncertainty (typical) <sup>g</sup>	N/A		±0.5 dB
Sweep measurement	Measurable power variation (typical) <sup>h</sup>	> 10 000 dB/nm at 100 nm/s		
	Optimum tunable laser sweep speed range	10 nm/s–200 nm/s		

a. Unless otherwise specified, after 1-hour warm-up (for the CTP10 mainframe and modules), at a constant temperature of 23 °C ± 1 °C, SMF28 patchcord, FC/APC connector, EXFO's continuously tunable laser used with SCAN SYNC module, at standard wavelength resolution.

b. When using SCAN SYNC, first and last 2.5 nm of the laser(s) wavelength scanning range are not usable. For O-band laser, last 5 nm are not usable.

c. Over one minute, within optimum tunable laser sweep speed range, laser optical power 10 dBm.

d. Tunable laser power 10 dBm, after zeroing of optical detector, averaging time set to Automatic and without FBC module in optical path.

e. For PDL < 2 dB and IL < 20 dB; 10 dBm TLS, auto average time, after zeroing of optical detectors, FC/PC connector to OPM. Higher PDL values can be displayed depending on measurement conditions.

f. ±0.04 dB + 1% PDL over spectral range 1490 nm to 1620 nm.

g. For RL < 40 dB, degree of polarization < 5%. Tunable laser power 10 dBm, after zeroing of optical detector, averaging time set to Automatic.

h. For IL < 45 dB, tunable laser power 10 dBm and averaging time set to 1  $\mu$ s.

SPECIFICATIONS <sup>a</sup>

OPTICAL AND PHOTOCURRENT MEASUREMENTS <sup>a</sup>		
OPMx Optical detectors	Sensor type	InGaAs
	Compatible fiber type	SMF28
	Compatible optical adaptors <sup>b</sup>	FC or SC connectors
	Maximum safe power	11 dBm
	Averaging time	Manual: 1 $\mu$ s to 1 s, automatic
	Display acquisition resolution	< 0.0001 dB
	Return loss (typical)	> 56 dB
PCMx Photocurrent meters	Measurement configuration	Grounded cathode, photovoltaic – no reverse bias <sup>c</sup>
	Photocurrent range <sup>d</sup> (single scan)	–85 dBmA to 10 dBmA
	Current uncertainty <sup>e,i</sup>	$\pm 1\%$
	Linearity <sup>f,i</sup>	$\pm 0.05$ dB $\pm 2$ pA
	Noise $2 \sigma$ <sup>g,i</sup> (at 10 nm/s)	8 dBmA to –20 dBmA: $\pm 0.005$ dB –20 dBmA to –40 dBmA: $\pm 0.010$ dB –40 dBmA to –50 dBmA: $\pm 0.015$ dB –50 dBmA to –60 dBmA: $\pm 0.050$ dB
	Noise $2 \sigma$ <sup>g,i</sup> (at 100 nm/s)	8 dBmA to –20 dBmA: $\pm 0.005$ dB –20 dBmA to –40 dBmA: $\pm 0.030$ dB –40 dBmA to –50 dBmA: $\pm 0.150$ dB –50 dBmA to –60 dBmA: $\pm 0.500$ dB
	Maximum safe current	11 dBmA
Connectors <sup>j</sup>	Triaxial 2-lug Pomona – center contact: anode; outer contact: cathode; shield: ground	
PCMx accessories	Photodiode <sup>h</sup>	InGaAs, 1 mm diameter photodiode compatible with FOA adaptor
	Triaxial cable	3 m long triaxial cable with triaxial 2 lug connectors

a. Unless otherwise specified, after 1-hour warm-up (for the CTP10 mainframe and modules), at a constant temperature of  $23 \text{ }^\circ\text{C} \pm 1 \text{ }^\circ\text{C}$ , SMF28 patchcord, FC/APC connector, EXFO's continuously tunable laser used with SCAN SYNC module.

b. Fiber Optic Adaptor (FOA) included with OPMx module, also available as accessory.

c. Specifications given when PCM is used with EXFO's triaxial cable and photodiode. Any bias applied to the PCM could damage electronics. Only connect one photodiode per PCM port.

d. The photocurrent range is defined as the saturation current limit down to six times the rms noise. In static measurement mode. After zeroing of photocurrent meter. With automatic averaging.

e. At characteristic value at –20 dBmA detection level, fixed current measurement, after zeroing and within one year after calibration.

f. Between –70 dBmA and 8 dBmA, current referenced at –30 dBmA, after zeroing, excluding noise and offset drifts, with EXFO triaxial cable <3 m in length and within one year after calibration.

g. With EXFO photodiode capacitance < 90 pF and with EXFO triaxial cable < 3 m in length (excluding fluctuations from laser source).

h. One FOA included, also available as accessory.

i. Characteristics specification describe product performance that is typical of the majority of a given product (proportion of 80%). Typical specification is the average or median value of a parameter.

j. Designed to be connected to EXFO's triaxial cable and photodiode. For any other connection, please check with EXFO.



## SPECIFICATIONS—HARDWARE

Interfaces (rear panel of mainframe)	Display ports	2x (HDMI + display port) Compatible with split screen display and touchscreen with multitouch control	
	Remote	Ethernet (Option: GPIB)	
	Electrical inputs (hardware ready)	10x BNC	
	Electrical outputs (hardware ready)	7x BNC including 2 analog output ports	
	Other inputs	2x USB 2.0 and 2x USB 3.0	
Interfaces (front panel of mainframe)	Number of module slots	10	
	Other inputs	3x USB-A 2.0	
Data storage	Hard drive	HDD, 2 TB	
General	Temperature	Storage Operating	-20 °C to 65 °C (-4 °F to 149 °F) 5 °C to 40 °C (41 °F to 104 °F)
	Weight	Mainframe Module	8.5 kg (18.7 lb) 1 kg to 2.8 kg (2.2 lb to 6.2 lb)
	Dimensions (mainframe – H x W x D)		178 mm x 482 mm x 435 mm (7 in x 19 in x 17 in) 4U full rack with rackmount fixtures
	Power supply		100 V to 240 V AC (50/60 Hz)



## ORDERING INFORMATION

### MAINFRAME <sup>a</sup>

**CTP10 mainframe**

**CTP10-XX**

Example: CTP10-GPIB

**GPIB option** ■  
 00 = Without GPIB  
 GPIB = With GPIB

### DETECTORS & PHOTOCURRENT METERS

**OPMx module**

**OPMXX-XX**

Example: OPM6-FOA-322-EMC

**Number of detectors** ■  
 2 = 2 power meters  
 4 = 4 power meters  
 6 = 6 power meters

**Connector adaptor** ■  
 FOA-322-EMC = FC ultra-low-reflection: FC (PC/SPC/UPC/APC)  
 FOA-354-EMC = SC ultra-low-reflection: SC (PC/SPC/UPC/APC)

**PCMx module**

**PCMXX**

Example: PCM6

**Number of photocurrent meters** ■  
 2 = 2 photocurrent meters  
 6 = 6 photocurrent meters

### KEY MODULES

**IL RL OPM2 module**

**IL-RL-OPM2-58-XX**

Example: IL-RL-OPM2-58-FOA-322-EMC

**Connector adaptor** ■  
 FOA-322-EMC = FC ultra-low-reflection: FC (PC/SPC/UPC/APC)  
 FOA-354-EMC = SC ultra-low-reflection: SC (PC/SPC/UPC/APC)

**IL PDL module (2-slot module) <sup>b</sup>**

**IL-PDL-CL-58**

Example: IL-PDL-CL-58

**IL PDL OPM2 module (2-slot module) <sup>c</sup>**

**IL-PDL-OPM2-F-58-XX**

Example: IL-PDL-OPM2-F-58-FOA-322-EMC

**Connector adaptor** ■  
 FOA-322-EMC = FC ultra-low-reflection: FC (PC/SPC/UPC/APC)  
 FOA-354-EMC = SC ultra-low-reflection: SC (PC/SPC/UPC/APC)

### WAVELENGTH CONTROL

**SCAN SYNC module**

**SCAN-SYNC-58**

Example: SCAN-SYNC-58

**Full-band combiner module**

**FBC-XX-58**

Example: FBC-M-58

**Fiber type** ■  
 00 = single-mode fiber  
 M = polarization-maintaining fiber <sup>b</sup>

a. All 1-slot module except for the 2-slot module IL PDL CL and IL PDL OPM2.

b. This module operates with tunable lasers with polarization maintaining fiber output.

c. This module operates with tunable lasers with polarization maintaining fiber output. Use an FBC-M module if several PM lasers need to be combined.

## ACCESSORIES

### Wavelength reference gas cells

WLRM-NS270XX

Spectral reference range

1 = C-band  
2 = O-band

Example: WLRM-NS2701

### PDH1 InGaAs photodiode remote head<sup>a</sup>

PDH1-XX

Connector adaptor

FOA-322-EMC = FC ultra-low-reflection FC (PC/SPC/UPC/APC)  
FOA-354-EMC = SC ultra-low-reflection SC (PC/SPC/UPC/APC)  
LOA = 3.7 mm clear aperture lensed adaptor

Example: PDH1-FOA-322-EMC

a. Triaxial cable sold as a separate accessory.

**EXFO headquarters** T +1 418 683-0211 **Toll-free** +1 800 663-3936 (USA and Canada)

EXFO serves over 2000 customers in more than 100 countries. To find your local office contact details, please go to [www.EXFO.com/contact](http://www.EXFO.com/contact).

For the most recent patent marking information, please visit [www.EXFO.com/patent](http://www.EXFO.com/patent). EXFO is certified ISO 9001 and attests to the quality of these products. EXFO has made every effort to ensure that the information contained in this specification sheet is accurate. However, we accept no responsibility for any errors or omissions, and we reserve the right to modify design, characteristics and products at any time without obligation. Units of measurement in this document conform to SI standards and practices. In addition, all of EXFO's manufactured products are compliant with the European Union's WEEE directive. For more information, please visit [www.EXFO.com/recycle](http://www.EXFO.com/recycle). **Contact EXFO for prices and availability or to obtain the phone number of your local EXFO distributor.**

For the most recent version of this spec sheet, please go to [www.EXFO.com/specs](http://www.EXFO.com/specs).

In case of discrepancy, the web version takes precedence over any printed literature.